

# Models

**GP8055, GP8055-1000,  
GP8060, GP8060-1000,  
GP8065 and GP8065-1000**

---

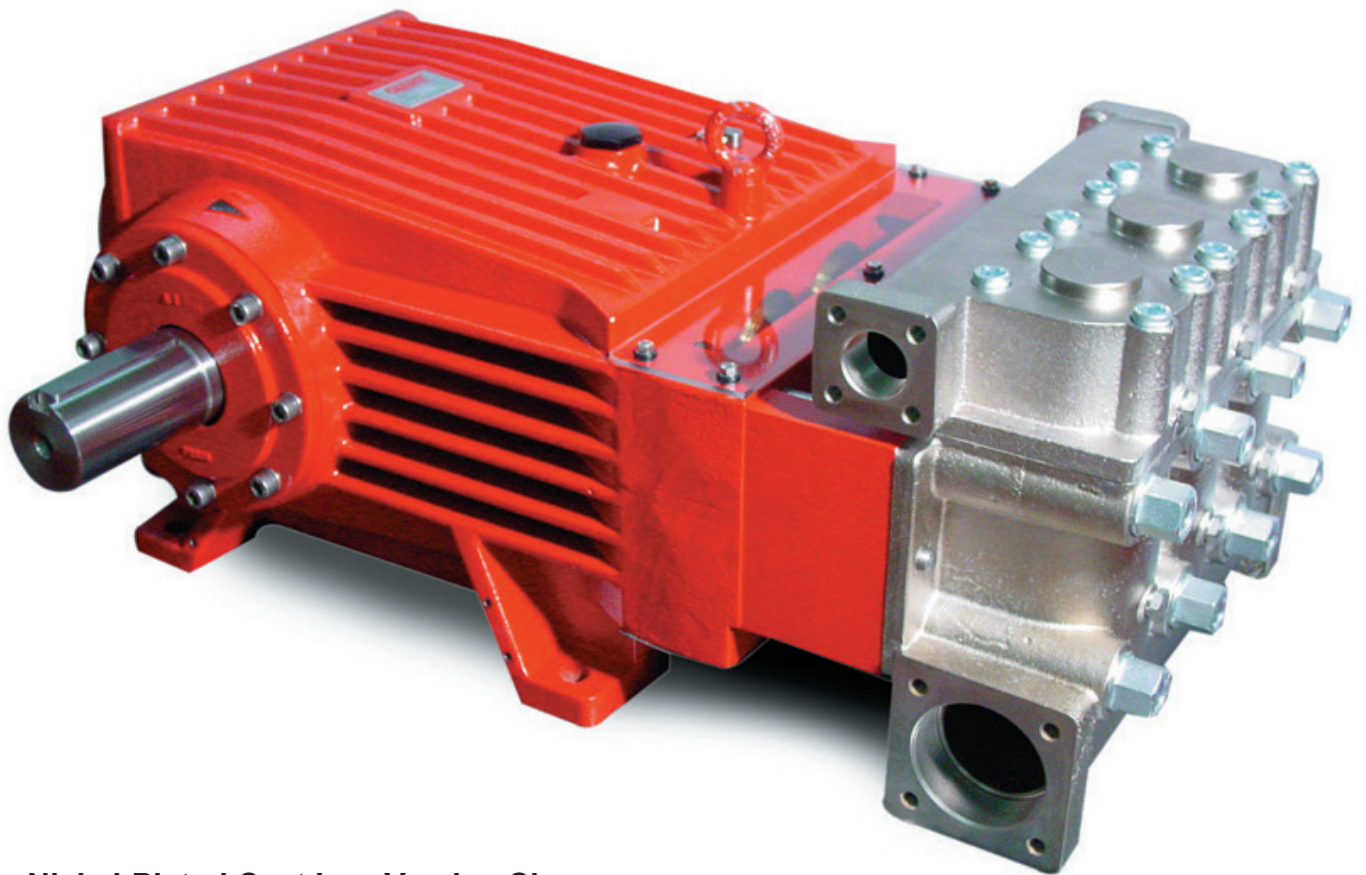

Nickel-Plated Cast Iron Version Shown

---

**GIANT**  
Performance Under Pressure

**Contents:**

Installation Instructions:	page 2
Pump Specifications:	page 3-5
Exploded View/Parts List:	pages 6-7
Repair Kits/Tool List:/Torque Specifications	page 8
Troubleshooting Chart:	page 8
Repair Instructions:	pages 9-11
Dimensions:	back page
Warranty Information	back page

Updated 08/23

# INSTALLATION INSTRUCTIONS

The stated figures are for maximum pressure and maximum speed (rpm) and apply for interval operation with cold water. Required NPSH refers to water (specific weight 1kg/dm<sup>3</sup>, viscosity 1°E) at maximum permissible pump revolutions. Fluid medium: Clean water filtered to 50µm.

## Operation and Maintenance

Check oil level prior to starting and ensure trouble-free water supply.

**IMPORTANT!** If there is a danger of frost, the water in the pump and in the pump fittings (particularly the unloader valve) must be emptied. The second discharge port can also be used and the pump run "dry" for 1-2 minutes for this purpose. Oil: Use only 3.3 gallons (12.5 liters) of Giant Oil (p/n 01154) or ISO VG 220 GL4 (e.g. Aral Degol BG220) or SAE 90 GL4 gear oil. Initial change after 50 operating hours and then every 1000 operating hours or after one year of operation.

**IMPORTANT!** when operating in damp places or with high temperature fluctuations. Oil must be changed immediately should condensate (frothy oil) occur in the gear box.

**NPSH values must be observed**

## Cooling the Gear Oil

**IMPORTANT!** When using the integrated cooling system for cooling the gear oil, the water inlet pressure must not exceed 29 PSI (2 bar).

If a separate cooling circuit is installed, it is then possible to have an inlet pressure up to a maximum of 145 PSI (10 bar) on the inlet side.

Make sure that suction pulsation is sufficiently dampened – water column resonance must be avoided.

**IMPORTANT!** The pumps can be run without gear oil cooling in continuous operation **up to a power rating of 107 hp (80 kW)** or with major intermittent operation at full performance (see below regarding the definition for intermittent operation). If operational power exceeds **107 hp (80 kW)** or if continuous operation is the case, the pump must be run with the integrated oil cooling system.

**Definition of intermittent operation:** operation at full performance for not more than 20 minutes in any given hour. In between the pump is running without pressure or turned off. For example, this can be full load operation for 5 minutes four times an hour with 10 minute breaks in between or continuous full load operation for 20 minutes followed by a 40 minute break.

The maximum temperature of the water being pumped and which is also fed through the cooling system must not exceed 86 °F (30 °C). The water amount which is fed into the cooling system depends on the pump speed and is approximately 1.85 gpm (7.0 l/min.) at 580 pump rpm. The cooling water is sucked in by one of the pumping chambers and pumped away.

**IMPORTANT!** If higher medium temperatures or liquids other than water are involved or aggressive media such as seawater, demineralised water etc., the pump must be fitted with a separate cooling circuit. The separate cooler must have a cooling efficiency of 1700 watt. If there is a danger of frost, an appropriate amount of antifreeze must be mixed into the cooling circuit.

When starting up for work, the pump must run first at zero pressure for approximately 1 minute.

**IMPORTANT!** The GP8000 series has a black arrow on the crankcase which shows the preferred direction of rotation. The preferred direction of rotation ensures oil is splashed onto the crosshead guides in the correct manner via the motion of the connecting rods – which is a particular advantage where

continuous operation is involved.

The pump can also be run against the recommended direction of rotation if operated periodically or at reduced pressure. If so, the pump must be run in in this direction to smoothen the bearing areas. This is done by initially operating the pump at zero pressure for 30 minutes; thereafter the pressure is to be slowly increased over a period of an hour to the desired maximum operating pressure. Check the oil temperature during this process.

**IMPORTANT!** If there is a danger of frost, the pump and cooling system must be emptied. Note that travel wind can cause water in pumps fitted on open vehicles to freeze even if the outside temperature is above freezing point.

To empty the cooling circuit, remove the L-joints (K11) on the pump head (50). Blow out the circuit liquid at the joint connection (K11/K7) using compressed air.

The torque tension on the valve casing nuts (49A) is to be checked after approximately 200 operating hours. Please see page 8 for torque specifications.

When checking the torque tension, the pump must be at zero pressure.

**IMPORTANT!** The service life of the seals is maximized if a minimal amount of leakage is present. A few drops of water can drip from each plunger every minute. Leakage has to be examined every day; the plunger seals must be changed should leakage become excessive i.e. constant dripping.



## Safety Rules

**The operating instructions must be read and adhered to before performing any work on the pump or complete assembled unit. No responsibility will be carried by us for damage to materials or persons caused by improper handling of our pumps.**

Access to the pump is not allowed for unauthorized personnel. A safety valve is to be installed in accordance with the guidelines for liquid spraying units so that the admissible operating pressure cannot be exceeded by more than 10%. Pump operation without a safety valve as well as any excess in temperature or speed limits automatically voids the warranty.

When the pump is in operation, the driven shaft side and its coupling must be covered by a protective guard. The plunger area must also be covered by the protective plate (30).

Do not step onto the protective plate (30) or put weight on it. Pressure in the discharge line and pump must be at zero before carrying out any maintenance work to the pump or unit. Close off suction line. Disconnect fuses to ensure that the driving motor cannot be accidentally switched on. Make sure that the pump, the cooling system and all parts on the pressure side of the unit are vented and refilled, with pressure at zero, before starting the pump.

In order to prevent air or an air/water-mixture being absorbed and cavitation occurring, the pump npshr (net positive suction head required) and water temperature must be respected.

**Cavitation and/or compression of gases lead to uncontrollable pressure-kicks which can ruin the pump and unit parts and also be dangerous to the operator or anyone standing nearby.**

Giant plunger pumps are suitable for pumping clean water and other non-aggressive or non-abrasive media with a specific weight similar to water.

**Before pumping other liquids - especially inflammable, explosive and toxic media - the pump manufacturer must be consulted with regard to the resistance of the pump material. It is the responsibility of the equipment manufacturer and/or operator to ensure that all pertinent safety regulations are followed.**

# Specifications

## Models GP8055 / GP8055-1000

	U.S.	(Metric)
Flow .....	75.3 GPM .....	(285 LPM)
Discharge Pressure .....	3000 PSI .....	(200 bar)
Power Consumption .....	145 BHP .....	108 kW
Maximum Speed.....	580 RPM.....	580 RPM
Inlet Pressure.....	29 PSI .....	(2.0 bar)
Plunger Diameter.....	2.17".....	55 mm
Plunger Stroke .....	2.83".....	72 mm
Crankshaft Diameter.....	2.76".....	70 mm
Key Width .....	0.55".....	14 mm
Crankshaft Mounting.....		Either side
Shaft Rotation .....		Top of pulley towards manifold
Temperature of Pumped Fluids.....	86° F .....	(30° C)*
Inlet Ports.....		(2) 3" BSP
Discharge Ports .....		(2) 1-1/4" BSP
Weight.....	749 lbs. ....	(340 kg)
Crankcase Oil Capacity .....	3.3 Gal. ....	(12.5 liters)
Valve Casing Material (GP8055) .....		Nickle plated Spheroidal Cast Iron
Valve Casing Material (GP8055-1000) .....		Aluminum-Bronze
NPSHR .....	23.0 ft.-head.....	7.0 mWs

\*higher water temperatures possible with separate crankcase cooling system; contact Giant.

Consult the factory for special requirements that must be met if the pump is to operate beyond one or more of the limits specified above.

<b>GP8055/GP8055-1000 HORSEPOWER REQUIREMENTS</b>					
RPM	GPM	500 PSI	1000 PSI	2000 PSI	3000 PSI
300	38.9	13.4	26.8	53.7	80.5
400	51.9	17.9	35.8	71.6	107.4
500	64.9	22.4	44.1	89.5	134.3
580	75.3	26.0	51.9	103.9	155.8

**SPECIAL NOTE:**  
The theoretical gallons per revolution (gal/rev) is 0.130. To find specific outputs at various RPM, use the formula:  
$$GPM = 0.130 \times RPM$$

### HORSEPOWER RATINGS:

The rating shown are the power requirements for the pump. Gas engine power outputs must be approximately twice the pump power requirements shown above.

We recommend a 1.15 service factor be specified when selecting an electric motor as the power source. To compute specific pump horsepower requirements, use the following formula:

$$\frac{GPM \times PSI}{1450} = HP$$

# Specifications

## Model GP8060 / GP8060-1000

	U.S.	(Metric)
Flow .....	90 GPM .....	(340 LPM)
Discharge Pressure .....	2465 PSI .....	(170 bar)
Power Consumption .....	147 BHP .....	110 kW
Maximum Speed.....	580 RPM.....	580 RPM
Inlet Pressure.....	29 PSI .....	(2.0 bar)
Plunger Diameter.....	2.36".....	60 mm
Plunger Stroke .....	2.83".....	72 mm
Crankshaft Diameter.....	2.76".....	70 mm
Key Width .....	0.55".....	14 mm
Crankshaft Mounting.....		Either side
Shaft Rotation .....		Top of pulley towards manifold
Temperature of Pumped Fluids.....	Up to 86° F .....	(30° C)*
Inlet Ports.....		(2) 3" BSP
Discharge Ports .....		(2) 1-1/4" BSP
Weight.....	749 lbs. ....	(340 kg)
Crankcase Oil Capacity .....	3.3 Gal. ....	(12.5 liters)
Valve Casing Material (GP8060) .....		Nickle plated Spheroidal Cast Iron
Valve Casing Material (GP8060-1000) .....		Aluminum Bronze
NPSHR .....	26.2 ft.-head.....	8.0 mWs

\*higher water temperatures possible with separate crankcase cooling system; contact Giant.

Consult the factory for special requirements that must be met if the pump is to operate beyond one or more of the limits specified above.

<b>GP8060/GP8060-1000 HORSEPOWER REQUIREMENTS</b>					
RPM	GPM	500 PSI	1000 PSI	2000 PSI	2500 PSI
300	46.0	15.9	31.7	63.5	79.3
400	61.4	21.2	42.3	84.7	105.9
500	76.7	26.5	52.9	105.8	132.2
580	89.0	30.7	61.4	122.8	153.5

**SPECIAL NOTE:**  
The theoretical gallons per revolution (gal/rev) is 0.153. To find specific outputs at various RPM, use the formula:  
$$\text{GPM} = 0.153 \times \text{RPM}$$

**HORSEPOWER RATINGS:**

The rating shown are the power requirements for the pump. Gas engine power outputs must be approximately twice the pump power requirements shown above.

We recommend a 1.15 service factor be specified when selecting an electric motor as the power source. To compute specific pump horsepower requirements, use the following formula:

$$\frac{\text{GPM} \times \text{PSI}}{1450} = \text{HP}$$

# Specifications

## Model GP8065 / GP8065-1000

	U.S.	(Metric)
Flow .....	105.7 GPM	(400 LPM)
Discharge Pressure .....	2000 PSI	(140 bar)
Power Consumptions.....	142 BHP	106 kW
Maximum Speed.....	580 RPM	580 RPM
Inlet Pressure.....	29 PSI	(2.0 bar)
Plunger Diameter.....	2.55"	65 mm
Plunger Stroke .....	2.83"	72 mm
Crankshaft Diameter.....	2.76"	70 mm
Key Width .....	0.55"	14 mm
Crankshaft Mounting.....		Either side
Shaft Rotation .....		Top of pulley towards manifold
Temperature of Pumped Fluids.....	Up to 86° F	(30° C)*
Inlet Ports.....		(2) 3" BSP
Discharge Ports .....		(2) 1-1/4" BSP
Weight.....	749 lbs.	(340 kg)
Crankcase Oil Capacity .....	3.3 Gal.	(12.5 liters)
Valve Casing Material (GP8065) .....		Nickle plated Spheroidal Cast Iron
Valve Casing Material (GP8065-1000) .....		Aluminum Bronze
NPSHR .....	23.6 ft.-head	7.2 mWs

\*higher water temperatures possible with separate crankcase cooling system; contact Giant.

Consult the factory for special requirements that must be met if the pump is to operate beyond one or more of the limits specified above.

<b>GP8065/GP8065-1000</b>					
<b>HORSEPOWER REQUIREMENTS</b>					
RPM	GPM	500 PSI	750 PSI	1000 PSI	2000 PSI
300	54.7	18.9	28.3	37.7	75.5
400	72.9	25.1	37.7	50.3	100.6
500	91.1	31.4	47.1	62.8	125.7
580	105.7	36.5	54.7	72.9	145.8

### HORSEPOWER RATINGS:

The rating shown are the power requirements for the pump. Gas engine power outputs must be approximately twice the pump power requirements shown above.

We recommend a 1.15 service factor be specified when selecting an electric motor as the power source. To compute specific pump horsepower requirements, use the following formula:

$$\frac{\text{GPM} \times \text{PSI}}{1450} = \text{HP}$$

### SPECIAL NOTE:

The theoretical gallons per revolution (gal/rev) is 0.182. To find specific outputs at various RPM, use the formula:

$$\text{GPM} = 0.182 \times \text{RPM}$$





# Part List - GP8055 (-1000), GP8060 (-1000), GP8065 (-1000)

Item	Part	Description	Qty	Item	Part	Description	Qty
1	05380	Crankcase	1	43	05278	Sleeve Support Ring (GP8055)	3
2	06893	Oil Filler Plug Assy with Vent	1	43	05070	Sleeve Support Ring (GP8060)	3
5	22929	Copper Washer	2	43	05118	Sleeve Support Ring (GP8065)	3
6	12256	Plug, 3/8" BSP	1	45	05279	Seal Tension Spring (GP8055)	3
7	05656	Plug for oil dipstick	1	45	05071	Seal Tension Spring (GP8060)	3
8	05035*	Oil Dipstick Assy	1	45	05119	Seal Tension Spring (GP8065)	3
9	01009	O-Ring	1	49	05072	Stud Bolt	8
12	07109	Plug 1/2" BSP	2	49A	05073	Hexagon Nut	8
13	06272	Seal	2	50	05074	Valve Casing (GP8055/60/65)	1
14	05036	Bearing Cover Closed	1	50	05074-3000	Valve Casing (-1000 Versions)	1
14A	05298	Bearing Cover Open	1	50A	13162	Centering Stud	2
15	05112	Radial Shaft Seal	1	50B	05075	Discharge Valve Casing (GP8055/60/65)	1
16	05037	O-Ring	2	50B	05075-3000	Discharge Valve Casing (-1000 Versions)	1
17	05038	Hexagon Socket Screw	16	51	04186	Suction Valve Assembly	3
18	05039	Spring Ring	16	51A	04166	Spring Tension Cap	3
21	05044	Tapered Roller Bearing	2	51B	05078	Suction Valve Seat	3
21A	05042	Fitting Disc	1-5	51C	05079	Valve Plate	3
21B	05043	Fitting Disc	1-5	51D	07658	O-Ring	3
21C	05113	Fitting Disc	1-5	51E	05080	Valve Spring	3
22	05299	Crankshaft	1	52	04188	Discharge Valve Assy	3
23	05300	Fitting Key	1	52A	04166	Spring Tension Cap	3
24	05047	Conn-rod Assy	3	52B	05084	Discharge Valve Seat	3
25	05048	Crosshead c/w Plunger	3	52C	05079	Valve Plate	3
28	05049	Crosshead Pin	3	52D	06258	O-Ring	6
29	05051	Hexagon Screw	5	52E	05080	Valve Spring	3
29A	05381	Bracket 1 for Cooling Hose	2	56	05085	Discharge Valve Adaptor	3
29B	05383	Bracket 2 for Cooling Hose	2	56A	06258	O-Ring	3
30	05052	Cover Plate	1	57	05086	Pressure Spring	3
30A	07225-0100	Hexagon Screw	5	57A	07210-0100	Pressure Spring	3
30B	13136	Grommet	5	58	05087	Hexagon Socket Screw	12
30C	08280	Washer	10	59	07109	Plug 1/2" BSP	1
30D	05050	Splash Cover	1	59A	06272	Copper Seal	1
31	07623	Eye Bolt	3	60	06909	Plug 1-1/4" BSP	1
32	05058	Radial Shaft Seal	3	61	05088	Plug 3" BSP	1
32A	03118	Scraper	3	62	05302	Plug 1/4" BSP	6
33	03119	Seal Retainer	3	62A	06934	Copper Gasket	6
33A	05056	O-Ring	3	66	05303	Disc for Crankshaft	1
33B	05054	Clip Ring	3	67	13433	Hexagon Screw	1
33C	05059	Fitting Disc	3	78	05025	Oil Cooler Assembly	1
34	05060	Oil Shield	3	K1	05026	Cooling Vane Plate	1
36A	05063	Cover for Plunger Pipe (GP8060/GP8065)	3	K2	05027	Seal for Gear Cover	2
36B	05280	Plunger Pipe (GP8055)	3	K3	05028	Gear Cover	1
36B	05061	Plunger Pipe (GP8060)	3	K4	05029	Hexagon Head Countersunk Screw	8
36B	05115	Plunger Pipe (GP8065)	3	K5	07381	Hexagon Socket Screw	6
36C	05062	Tension Screw	3	K6	08041	Washer	6
36D	07665	Copper Washer	3	K7	05030	Connection for Oil Cooler	1
36E	06900	Centering Sleeve	3	K8	06272	Copper Seal	6
38	05283	Seal Case (GP8055)	3	K9	07109	Plug 1/2" BSP	2
38	05064	Seal Case (GP8060/GP8065)	3	K10	05031	Connecting Branch	3
38A	13286	O-Ring (GP8055)	6	K11	05032	Hose Adaptor	4
38A	06667	O-Ring (GP8060/GP8065)	6	K12	05033	Tube for Cooler	2
38B	05281	Support Ring (GP8055 Only)	6	K13	05402	Hose Clamp	4
39	05275	Seal Sleeve (GP8055)	3	K14	05403	Hose Guard	2
39	05065	Seal Sleeve (GP8060)	3	K15	05404	Hose Coupling Nut	1
39	05116	Seal Sleeve (GP8065)	3	K16	05405	Flat Gasket	4
39A	05066	O-Ring	3	K18	04158	Hexagon Socket Screw	4
40	07723	Seal Ring (GP8055)	3	K19	05053	Washer	4
40	05067	Seal Ring (GP8060)	3	05605	05605	Gear End Assembly (1-34,49,49A,50,66,67)	
40	06996	Seal Ring (GP8065)	3	05606	05606	Manifold Assembly (50-62A, without 50A) (GP8055/GP8060/GP8065)	
41	05276	Pressure Ring (GP8055)	3	05606-1000	05606-1000	Manifold Assembly (50-61, without 50A) (-1000 Versions)	
41	05068	Pressure Ring (GP8060)	3	05208	05208	Plunger Replacement Kit (GP8055/-1000)	
41	05117	Pressure Ring (GP8065)	3	05207	05207	Plunger Replacement Kit (GP8060/-1000)	
42	05277	V Sleeve (GP8055)	9	05209	05209	Plunger Replacement Kit (GP8065/-1000)	
42	05069	V Sleeve (GP8060)	9				
42	06997	V Sleeve (GP8065)	9				
	*17422	Add optional extended dip stick assembly (sold separately)					

# GP8055(-1000)/GP8060(-1000)/GP8065(-1000) PUMP REPAIR KITS

## Plunger Packing Kits

### GP8055 - #09616

Item	Part #	Description	Qty.
38A	13286	O-Ring	6
38B	05281	Support Ring	6
39A	05066	O-Ring	3
40	07723	Seal Ring	3
42	05277	V-Sleeve	9

### GP8060 - #09617

Item	Part #	Description	Qty.
38A	06667	O-Ring	6
39A	05066	O-Ring	3
40	05067	Seal Ring	3
42	05069	V-Sleeve	9

### GP8065 - #09586

Item	Part #	Description	Qty.
38A	06667	O-Ring	6
39A	05066	O-Ring	3
40	06996	Seal Ring	3
42	06997	V-Sleeve	9

### Inlet Valve Kit - #09587

Item	Part #	Description	Qty.
51	04186	Inlet Valve Assembly	3
56A	06258	O-Ring	3

## Discharge Valve Kit - #09588

Item	Part #	Description	Qty.
52	04188	Discharge Valve Assembly	3
56A	06258	O-Ring	3

## Oil Seal Kit - #09584A

(From 06/19)

Item	Part #	Description	Qty.
32	05058	Radial Shaft Seal	3
32A	03118	Scraper	3
33A	05056	O-Ring	3

## Oil Seal Kit - #09584

(Prior to 06/19)

Item	Part #	Description	Qty.
32	05058	Radial Shaft Seal	3
33A	05056	O-Ring	3

## Oil Seal Kit - #09584-R

(To retrofit pumps made before middle of 2019)

Item	Part #	Description	Qty.
32	05058	Radial Shaft Seal	3
32A	03118	Scraper	3
33	03119	Seal Retainer	3
33A	05056	O-Ring	3

GP8055/GP8060/GP8065 TOOL LIST AND TORQUE SPECIFICATIONS				
ITEM	PART #	DESCRIPTION	TORQUE Ft-lbs (NM)	TOOL NEEDED
17	05038	Hexagon Socket Screw	64 (87)	10mm allen wrench
24	05047	Connecting Rod Hexagon Socket	37 (50)	8mm allen wrench
33B	05054	Clip Ring	n/a	Industrial Snap ring pliers
36C	05062	Tension Screw	30 (40)	19mm socket
49A	05073	Hexagon Nut (manifold)	266 (360)	30mm socket
51/52	05084/05076	Valve Assemblies	n/a	Valve puller (p/n 07662) - included with pump
58	05087	Hexagon Socket Screw	133 (180)	12mm allen wrench
K5	07381	Hexagon Socket Screw	n/a	8mm allen wrench

GP8000 Troubleshooting		
Problem	Cause	Solution
Pressure drops, water leaks	V-sleeves leak	Replace V-sleeves, examine surface of plunger
Pressure drops, pump becomes loud	Discharge or suction valve leaks	Replace valve
	Steam formation (cavitation)	Reduce suction height, reduce flow resistance in inlet line, clean inlet filter, lower water temperature
Irregular pressure	Worn valves	Examine valves
	O-Ring on the valves or inlet valve adapter leaks	Examine O-ring, examine valve casing for unevenness on the sealing surfaces
Oil leaks at visible part of plunger	Gear sealing is leaky	Examine seals and running surface of plunger
Dirty mile-colored frothy oil	Oil has mixed with water	Replace oil immediately, find and fix the cause
Oil leakage on the crankshaft	Shaft seal ring leaks	Check seal and shaft
Noise increases without loss of pressure	Worn bearing	Dismantle gear, examine all parts, replace worn parts, check oil level. If service life was too short, check for excess strain or whether lubrication intervals were too long. Only specified lubricants are to be used



# GP8055(-1000)/GP8060(-1000)/GP8065(-1000) PUMP REPAIR INSTRUCTIONS

## Valve Inspection and Repair

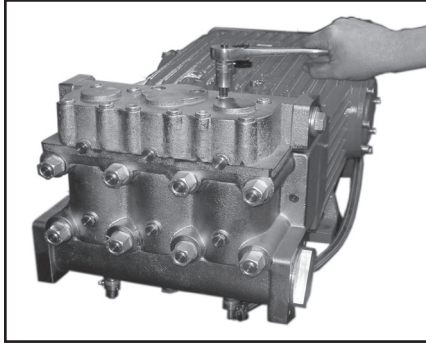

1) Remove bolts (58).

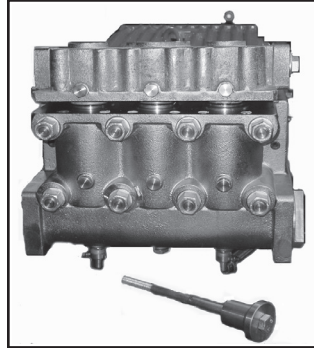

2) Remove discharge casing (50B) up and away.

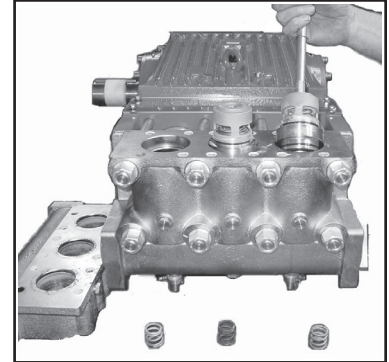

3) Take out pressure springs (57A). Pull out assembled valves (51 & 52) with valve pulling tool (07662).

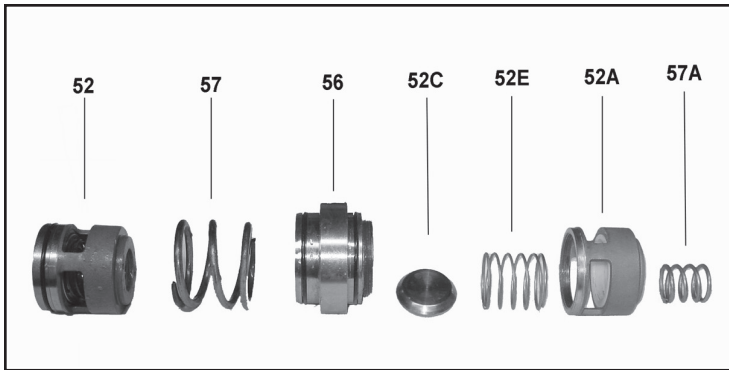

4) The spring tension cap (51A, 52A) is screwed together with the valve seat (51B or 52B). Remove spring tension cap. Take-out springs (51E, 52E) and valve plate (51C, 52C). Check sealing surfaces and O-rings (51D, 52D). Replace worn parts. When reassembling, coat threads of valve seat with silicon grease or molycote anti-seize Cu-7439. Before refitting the valves, clean the sealing surfaces in the casing and check for any damage. Tighten bolts (58) to 133 Ft-lbs (180 Nm); check torque tension after 8-10 operating hours.

## To Check Seals and Plunger Pipe

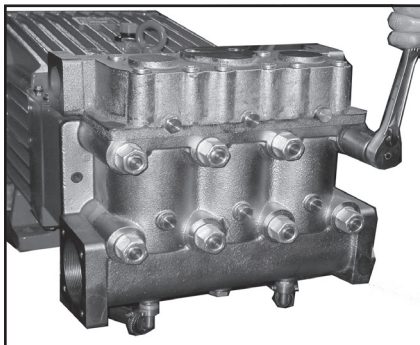

5) Remove hexagon nuts (49A) and valve casing together with seal case (38) from crankcase (1). If necessary, carefully tap the valve casing (50) past the centering stud (50A) using a rubber hammer.

**IMPORTANT!** If necessary, support the valve casing by resting it on wooden blocks or by using a pulley.

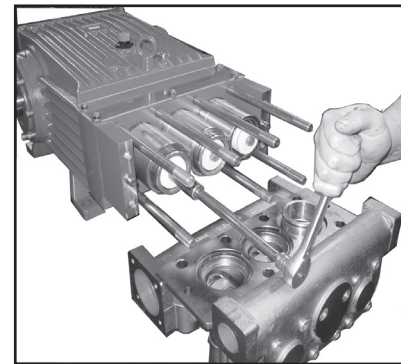

6) Remove tension screw (36C) and take seal sleeve (39) together with all mounted parts out of the drive. Pull plunger pipe out of the seal assembly and check for any damage. Carefully, remove seal rings (40) and sleeves (42) with a screw driver.

# GP8055(-1000)/GP8060(-1000)/GP8065(-1000) PUMP REPAIR INSTRUCTIONS

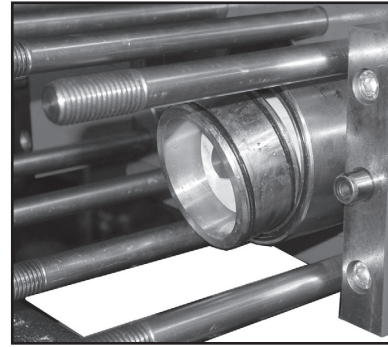
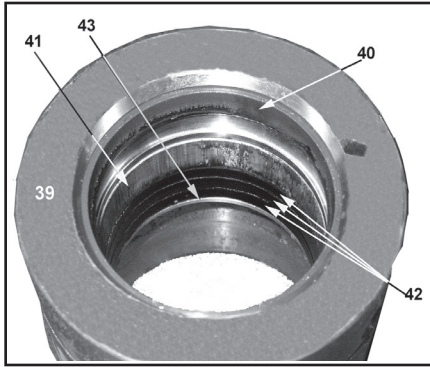

7) **Important!** Be careful not to damage the seal sleeve (39) and pressure ring (41). Check the inner diameter of the pressure ring for wear and if necessary replace together with seals (40) and (42). Clean all parts. New parts should be lightly coated with silicon grease before installation. Inert the seal unit (40, 41, 42 43) into the sleeve. Push the ceramic plunger carefully through the seals from the crankcase side. If necessary, the seals can be held tightly using a suitable pipe support held on the opposite side of the seal sleeve.

8) Take out the seal case (38) from the valve (if necessary secure 2 screwdrivers in the front O-ring groove to extract seal casing from valve casing). Coat seals with silicon grease before installing.

**Important!** Mounting surfaces of the crankcase and the valve casing must be clean and free of damage. The components must fit exactly and evenly on one another. The same exactness applies for all centering positions in the crankcase, pressure and valve casing.

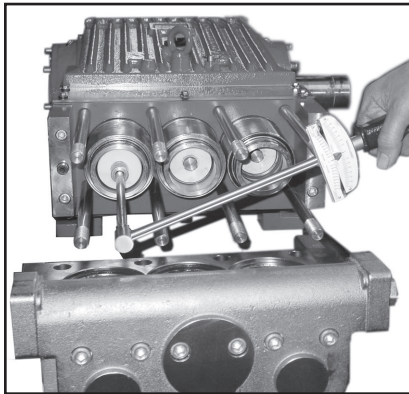

9) Lightly coat the seal sleeve with anti-corrosive grease (e.g. molycote no. Cu-7439) in its fitted area towards the crankcase. Insert the seal sleeves in to their crankcase fittings. Lightly coat the threads of the tension screw (36C) with thread glue and insert it together with a new copper ring (36D) through the ceramic pipe. Turn the pump by hand until the plunger (25) rests against the plunger pipe. Tighten the tension screw at 30 Ft-lbs. (40 Nm).

**Important!** Thread glue must never come between the plunger pipe (36B) and centering sleeve (36E). Overtensioning of the plunger pipe by excessive tightening of the tension screw and/or dirt or damage on the mounting surfaces can lead to plunger pipe breakage. Insert the seal tension spring (45) and O-ring (39A) in to the seal sleeve (39).

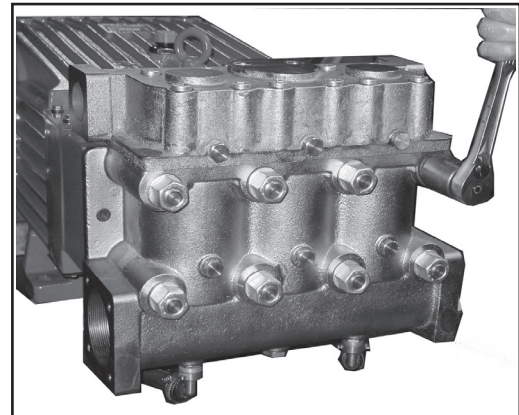

## Replacing Valve Casing:

10) Put seal cases (38) in the centering holes of the valve casing, then push valve casing carefully on to centering studs (50A). Tighten hexagon screws (49A) evenly and crosswise at 266 Ft.-lbs. (360 Nm).

**Important!** The torque tension on the screws (49A) must be checked after 8-10 operating hours; the pump must be at zero pressure. Thereafter, the tension is to be checked every 200 operating hours.

# GP8055(-1000)/GP8060(-1000)/GP8065(-1000) PUMP REPAIR INSTRUCTIONS

## To Dismantle Crankcase Gear

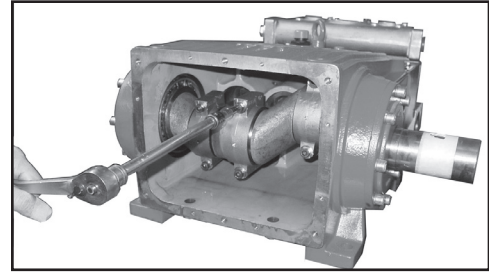
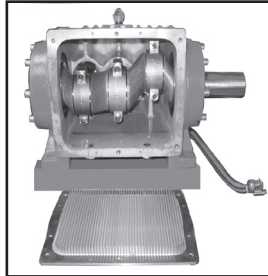
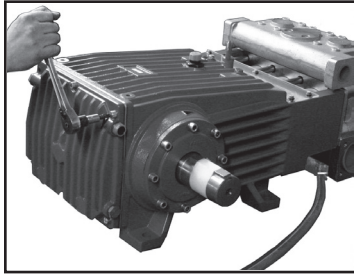

11) Take out plungers and seal sleeves as described above. Drain the oil by taking off the plug (12). After removing the clip ring (33B), pry out the seal retainer (33) with a screwdriver. Open hose adaptor (K11) and remove gear cover (K3) and the cooling vane plate (K1) by removing the screws (K4).

12) Remove the connecting rod screws (24).

**Important!** Connecting rods are marked 1 to 3 for identification. Do not twist connecting rod halves or interchange them. When reassembling, the connecting rod must be fitted in their exact original position on the crankshaft journals.

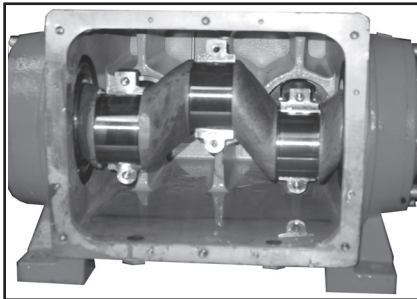

13) Push connecting rod halves together with the crosshead as far as possible into the crosshead guide. Take out bearing cover (14/14A) and push out crankshaft taking particular care that the con rod doesn't get bent. Check surfaces on the connecting rods (24), crankshaft (22) and crossheads (25). Check the surfaces of the crosshead guides in the crankcase for any unevenness.

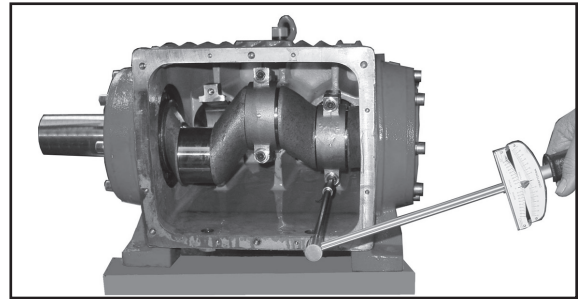

14) Reassemble in reverse order. Thread the long end of the crankshaft together with the inner bearing rings into the crankcase; then mount outer bearing ring (20) and spacer ring (22A). Mount connecting rod halves in their exact original position and tighten at 37 Ft-lbs. (50 Nm). **Important!** Connecting rods must be able to move slightly sideways on the stroke journals.

15) Mount bearing cover (14A) and tighten screws (17) to 64 Ft-lbs. (87 Nm). Adjust axial play (clearance) on the crankshaft to minimum 0.1 mm / max. 0.15 mm using shims (21A/21B). The shaft should turn easily with little clearance. Connecting rod must sit exactly in the middle of each crankshaft pin. Fit the bearing cover (14) and tighten the screws (17) at 64 Ft-lbs. (87 Nm). Seal (32A) must always be installed so that the seal lip on the inside diameter faces the oil.

**Important!** Possible axial float of the seal adaptor (33) is compensated with shims (33C).

Mount cooling plate (K1) and gear cover (K3) with their respective seals (K2). When assembling the cooling circuit line, make sure that the oil cooler connection (K7) is always joined to the upper connection (K3) of the gear cover.



## GP8055(-1000), GP8060(-1000), GP8065(-1000) SERIES DIMENSIONS - (mm)

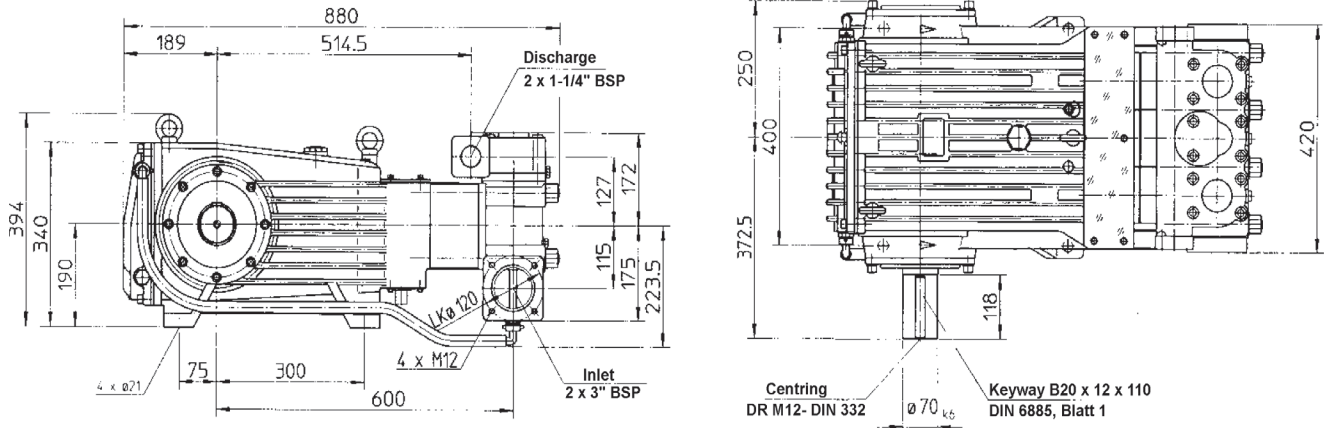

### GIANT INDUSTRIES LIMITED WARRANTY

Giant Industries, Inc. pumps and accessories are warranted by the manufacturer to be free from defects in workmanship and material as follows:

1. Five (5) years from the date of shipment for all pumps used in portable pressure washers with NON-SALINE, clean water applications.
2. Two (2) years from the date of shipment for Giant pumps used in car wash applications.
3. One (1) year from the date of shipment for all other Giant industrial and consumer pumps.
4. Six (6) months from the date of shipment for all rebuilt pumps
5. Ninety (90) days from the date of shipment for all Giant accessories.

This warranty is limited to repair or replacement of pumps and accessories of which the manufacturer's evaluation shows were defective at the time of shipment by the manufacturer. The following items are NOT covered or will void the warranty:

1. Defects caused by negligence or fault of the buyer or third party.
2. Normal wear and tear to standard wear parts.
3. Use of repair parts other than those manufactured or authorized by Giant.
4. Improper use of the product as a component part.
5. Changes or modifications made by the customer or third party.
6. The operation of pumps and or accessories exceeding the specifications set forth in the Operations Manuals provided by Giant Industries, Inc.

Liability under this warranty is on all non-wear parts and limited to the replacement or repair of those products returned freight prepaid to Giant Industries which are deemed to be defective due to workmanship or failure of material. A Returned Goods Authorization (R.G.A.) number and completed warranty evaluation form is required prior to the return to Giant Industries of all products under warranty consideration. Call (419)-531-4600 or fax (419)-531-6836 to obtain an R.G.A. number.

Repair or replacement of defective products as provided is the sole and exclusive remedy provided hereunder and the MANUFACTURER SHALL NOT BE LIABLE FOR FURTHER LOSS, DAMAGES, OR EXPENSES, INCLUDING INCIDENTAL AND CONSEQUENTIAL DAMAGES DIRECTLY OR INDIRECTLY ARISING FROM THE SALE OR USE OF THIS PRODUCT.

THE LIMITED WARRANTY SET FORTH HEREIN IS IN LIEU OF ALL OTHER WARRANTIES OR REPRESENTATION, EXPRESS OR IMPLIED, INCLUDING WITHOUT LIMITATION ANY WARRANTIES OR MERCHANTABILITY OR FITNESS FOR A PARTICULAR PURPOSE AND ALL SUCH WARRANTIES ARE HEREBY DISCLAIMED AND EXCLUDED BY THE MANUFACTURER.



**WARNING:** This product might contain a chemical known to the State of California to cause cancer, and birth defects or other reproductive harm.  
For more information go to [www.P65Warnings.ca.gov](http://www.P65Warnings.ca.gov)

**GIANT**  
Performance Under Pressure

**GIANT INDUSTRIES, INC.**

900 N. Westwood Ave.  
Toledo, Ohio 43607  
(419) 531-4600  
FAX (419) 531-6836  
[www.giantpumps.com](http://www.giantpumps.com)  
© Copyright 2023 Giant Industries, Inc.