

# Models

Triplex Ceramic  
Plunger Pump  
Operating Instructions/  
Repair and Service Manual

# LP800/ LP1000

---



## Contents:

General Information & Safety Instructions:	pages 2-3
Installation:	pages 3-5
Operation:	page 5
Repair Instructions:	pages 5-7
Pump Specifications:	pages 8-9
Exploded View:	page 10
Parts List / Kits:	page 11
Torque Specifications:	page 11
Pump Dimensions:	back page
Warranty Information:	back page

## 1. In General

### 1.1 Safety Rules

Pump operation without a safety valve as well as any excess in temperature or speed limits automatically voids the warranty. The safety valve must be regulated in accordance with the guidelines for liquid spraying units so that the admissible operating pressure can not be exceeded by more than 10%.

### 1.2 Fields of Use

The pump is suitable for conveying fresh, clean water (50 µm filtered) with a maximum temperature of 104°F (40°C).

Maximum operation pressure is attainable at 600 - 1000 rpm. Should the rpm fall below 600, the pump pressure must also be reduced proportionally to ensure proper gear lubrication.

## 2. Safety

This operation manual gives basic instructions which are to be observed during installation, operation and maintenance of the pump. It is therefore imperative that this manual be read by the responsible personnel/operator prior to assembly and commissioning. It is always to be kept available at the installation site. It is not only the general safety instructions contained under this main heading safety that are to be observed but also the specific information provided under the other main headings.

### 2.1 Identification of Safety Instructions in the Operating Manual

Safety instructions given in this manual, noncompliance with which would affect safety,

are identified by the following symbol:



see DIN 4844 - W9

or where electrical safety is involved, with



see DIN 4844 - W8

Safety measures which can cause damage to the machine if not adhered to, are marked

**Important!** It is imperative that signs affixed to the machine, e.g.,

- arrow indicating the direction of rotation
- symbols indicating fluid connections be observed and kept legible

### 2.2 Qualification and Training of Operating Personnel

The personnel responsible for operation, maintenance, inspection and assembly must be adequately qualified. Scope of responsibility and supervision of the personnel must be exactly defined by the plant operator. If the staff does not have the necessary knowledge, they must be trained and instructed, which may be performed by the machine manufacturer or supplier on behalf of the plant operator. Moreover, the plant operator is to make sure that the contents of the operating manual are fully understood by the personnel.

### 2.3 Hazards in the Event of Non-Compliance with the Safety Instructions

Noncompliance with the safety instructions may produce a risk to the personnel as well as to the environment and the machine and results in a loss of any right to claim damages.

For example, noncompliance may lead to the following hazards:

- Failure of important functions of the machine/plant
- Failure of specified procedures of maintenance and repair
- Exposure of people to electrical, mechanical and chemical hazards
- Endangering the environment owing to hazardous substances being released.

### 2.4 Compliance with Regulations pertaining to Safety at Work

When operating the pump, the safety instructions contained in this manual, the relevant national accident prevention regulations and any other service and safety instructions issued by the plant operator are to be observed.

### 2.5 Safety Instructions Relevant for Operation

- If hot or cold machine components involve hazards, they must be guarded against accidental contact.
- When the pump is in operation, the open shaft end must be covered by a shaft protector (21); the driven shaft side and coupling by a contact-protector.
- Guards for moving parts (e.g. shaft protector) must not be removed from the machine while in operation.
- Any leakage of hazardous fluids (e.g. explosive, toxic, hot) must be drained away to prevent risk to persons or the environment. Statutory regulations are to be complied with.
- Hazards resulting from electricity are to be prevented (e.g. see VDE Specifications and the bylaws of the local power supply utilities).

- Pressure in discharge line and in pump must be at zero before any maintenance to the pump takes place. Close off suction line.
- Disconnect fuses to ensure the driving motor does not get switched on accidentally.

Make sure all parts on the pressure side of the unit are vented and refilled, with pressure at zero, before starting the pump.

The following must be absolutely avoided: cavitation, and the priming and conveyance of any air or air/water mixture.

**Cavitation and/or compression of gases lead to uncontrollable pressure-kicks which can ruin pump and unit parts and also be dangerous to the operator or anyone standing nearby.**

- **Before pumping other liquids - especially inflammable, explosive and toxic media - the pump manufacturer must under all circumstances be consulted with regard to the resistance of the pump material. It is the responsibility of the equipment manufacture and/or operator to ensure that all pertinent safety regulations are adhered to.**

## 2.6 Safety Instructions for Maintenance, Inspection and Assembly Work

It shall be the plant operator’s responsibility to ensure that all maintenance, inspection and assembly work is performed by authorized and qualified personnel who have adequately familiarized themselves with the subject matter by studying this manual in detail.

Any work on the machine shall only be performed when it is at a standstill. Pumps and pump units which convey hazardous media must be decontaminated.

On completion of work, all safety and protective facilities must be reinstalled and made operative again. Prior to restarting the machine, the instructions listed under “Operation” are to be observed.

## 2.7 Unauthorized Alterations and Production of Spare Parts

Modifications to the machine can only be made after consultation with the manufacturer. Using spare parts and accessories authorized by the manufacturer is in the interest of safety. Use of other parts may exempt the manufacturer from any liability.

## 2.8 Unauthorized Modes of Operation

The reliability of the machine delivered will be only guaranteed if it is used in the manner intended, in accordance with clause 1 -In General- of this manual. The limit values specified in the data sheet must under no circumstances be exceeded.

### Pending Standards and other Data

DIN4844 Part 1:	Safety descriptions and supplement sheet 13
DIN4844 Part 1:	Safety descriptions and supplement sheet 14
	safety signs W8
	safety signs W9

## 3. Transport and Storage

The pump should always be transported horizontally. Storage for any length of time in a humid place or where temperatures are below zero is to be avoided. The storage room must be well ventilated.

## 4. Set-Up and Installation

The pump is to be mounted horizontally onto a solid frame that is also to accommodate the drive motor. The place of installation has to be chosen so that the belt drive and pump are made easily accessible for maintenance work (oil dip stick and oil filler plug must also be easy to reach).

### 4.1 Pump

**Important!** The preferred drive form is with toothed belts. Bare V-belts are admissible if the exact required belt tension can be kept. Excessive belt tension can lead to increased heating of the drive system and even to breakage of the crankshaft.

The direction of rotation of the pump is indicated by an arrow on both bearing flanges situated on the crankcase. The indicated direction of rotation must be observed to ensure that gear parts are properly lubricated.

## 4.1.1 Hydraulic Connections

### a) Suction Line

- On both sides of the pump head there is one 1/2" suction port and one 3/8" discharge port. Non-required port holes can be closed with the supplied plugs and bonding agent.
- Suction and discharge connections are to be fitted with elastic tubes to damp vibrations and guard the pump against pipeline tensions.
- The diameter of the suction line must be at least one size bigger than the suction inlet port.

**Important!** The pump is not to be connected directly to the water mains as gas bubbles present in fresh water can lead to premature wear and destruction of seals and valves. A feed tank with a volume at least 5 times greater than the pump discharge rate per minute is to be installed. The feed tank must be fitted with baffle plates to stop any air entering the tank and being passed on down to the suction port.

- The necessary input pressure of 36 PSI (2.5 bar) must be guaranteed using a centrifugal pump. A filter (maximum particle size 50 µm) with a volume at least 3 times greater than the pump discharge rate per minute must be fitted between the centrifugal pump and high pressure pump.

To check the required input pressure, we recommend the installation of a pressure gauge between the filter and high pressure pump.

**Important!** All screw connections must be tightly fixed to avoid any air entering into suction line. To avoid dirt entering into the pump head, the suction line should be thoroughly rinsed before being fixed to the suction port.

### b) Discharge Line

- The pump comes with two special conical seals (64) which have to be inserted in to the discharge ports of the pump. One of the two ports is to be closed with the included plug (65).
- The 1/2" BSP high-pressure hose connection for the discharge line must be constructed as per the below drawing to ensure that together with conical seal (64) the discharge line is completely sealed.
- We offer the high-pressure connection (p/n 05361) with UNF 9/16" female threads for high-pressure fittings.

The two 1/2" BSP connections on the top side of the valve casing are closed off with plug (62) and copper seal ring (63). These two connections are for the optional fitting of a pressure gauge and/or safety valve.

The copper ring (63) must remain in the bore should a pressure gauge or safety valve be installed. Trade pressure gauges with a 1/2" BSP connection have the appropriate contour so that the copper ring sits properly. We offer the double nipple (p/n 05362) for mounting the 23140 pressure relief valve.

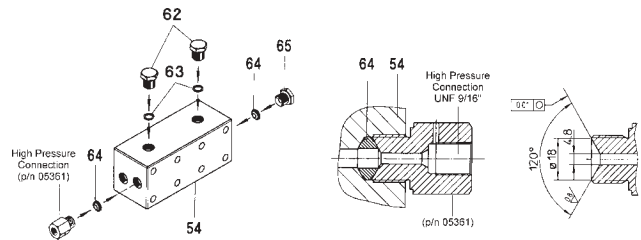

- Tubes, pipes and fittings of the discharge line must have a safety factor well above the maximum operating pressure.
  - Elastic hoses must be additionally secured by a firmly anchored safety net to avoid backlash in the event of a detachment or rupture of the hose.
  - A suitable safety valve must be installed immediately after the first length of flexible discharge line.
- There are to be no shut-off valves between the pump and safety valve.
- An air vent should be built into the discharge line as near as possible to the pump.
  - The most optimal place for installing a pressure gauge is between the pump and safety valve. The second outlet on the pump casing can also be used for this purpose.
  - The discharge line is to be layed either horizontally or rising steadily away from the pump.

Return flow lines from unloader valves and safety valves must be connected to the feed tank, never directly to the suction port

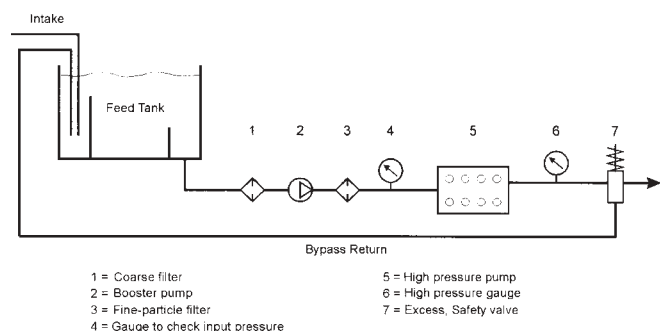

## 4.2 Pressure Accumulator

The purpose of the pressure accumulator, if installed, is to damp pulsation from the high pressure pump and thus avoid vibrations in the discharge line. Gas in the pressure accumulator should be tensioned to 50-60% of the maximum operating pressure. The correct gas tension must be checked regularly (approximately every 2 months - see separate operating instructions for pressure accumulator, if necessary).

## 5. Operation

### Operation and Maintenance

- Check pump oil level and if necessary fill up (as described on pages 8 and 9 hereof).

First oil change to be made after 50 hours of operation; thereafter oil must be changed every 500 operating hours - or at least every 6 months where 500 hours are not attained. Caution when operating in damp places or with high temperature fluctuations. Oil must be changed immediately should condensate (frothy oil) occur in the gear box.

- Before the high pressure pump is started, the centrifugal pump must produce the minimum intake pressure of 36 PSI (2.5 bar).
- Open discharge line (e.g. spray gun) to enable booster pump to vent the system.
- Open all regulator valves and other shut-off agents.
- Activate bypass system or switch pressure regulating valve to bypass to enable pressure-free start.
- Start motor briefly to check the direction of rotation. Pay careful attention to the direction of rotation that is specified for the pump (indicated by arrows on crankcase). To serve this purpose, the pump must only be dry run for a short period (approximately 30 seconds.).
- Start the pump and let it run in pressure-free bypass operation for approximately 2 minimum to enable the automatic- functioning seal cooling system to vent itself.

**Important!** A small portion of water from the suction chamber runs through the seal sleeves and steel elbow pipes and passes behind the high-pressure seals to cool these.

As a result of heat dissipation, the elbow pipes are approximately 41-50°F (5-10°C) warmer than the water temperature on the suction side.

**Important!** Check regularly to ensure elbow pipes do not overheat.

If pipes become very hot (indication of seal wear), stop pump immediately and examine seals and plungers (see maintenance section).

- Listen carefully for an even running sound.

If the pump begins to run irregularly or pulsate strongly, it can be that one of the three plungers is not vented. In this case, the pump should be started and stopped at short intervals to ease venting. Venting is also made easier if the vent tap in the discharge line is opened.

## 6. Maintenance and Repair

### To Check Valves:

**Discharge Valves:** Screw out hexagon screws (59) and remove valve casing (54). Pull seal case (46) out of valve casing (54). Pull valve body (50) and seal case (46) apart.

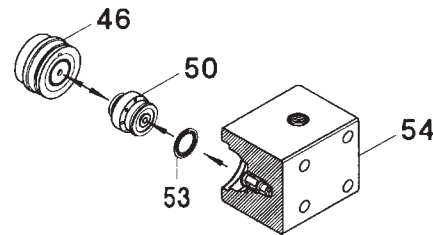

Using pliers, pull spring guide (55) out of the valve casing. Remove discharge valve plate (57) together with spring (56) from spring guide (55). Check sealing surfaces of the valve body (50) and discharge valve plate (57). Check discharge valve spring (56) and border seal ring (53) and replace where necessary.

**Important!** A damaged border seal ring (53) must be replaced before reassembling.

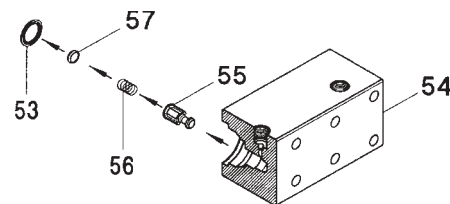

**Suction Valves: Remove** suction valve spring (48) with valve plate (49) from seal case (46). Check sealing surfaces of the valve plate (49) and valve body (50). Check O-rings (47), (51) and support ring (52) before reassembling. Worn parts must be replaced.

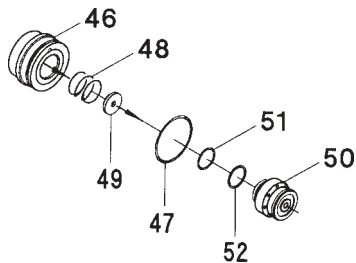

**To Check Seals and Plungers**

Unscrew hexagon screws (59), and take off valve casing (54). Remove the screw-in joints (37B) and take off the elbow pipes (37A). Remove drip-return ring (44) from seal sleeve (36). Pull seal sleeve (36) out of the crankcase.

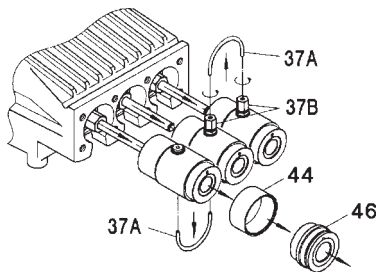

Take the seal tension spring (41) out of seal sleeve (36). Using a pliers, remove the clip ring (32) situated on the other side of the sleeve; then take out support ring (33) and grooved ring (35) using an extractor tool (either  $\phi 12$  or  $\phi 14$  - as per plunger  $\phi$ ). Using a seal extractor tool ( $\phi 12.4$  or  $\phi 14.4$  - as per plunger  $\phi$ ), carefully press the seal unit comprising guide ring (38), spiral ring (39) and support ring (40) out of the seal sleeve (36) from the side (36) closest to the drive. Check spiral ring (39), guide ring (38) and grooved ring (35) and replace where necessary.

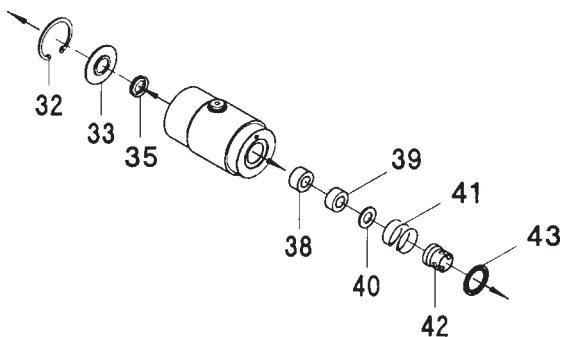

Check surface of plunger (29) for damage. A worn plunger (29) must be screwed out (key size 22) and replaced. Due to reasons of precision, the ceramic plunger alone cannot be exchanged.

Coat the threads of the plunger lightly with an appropriate bonding agent and tighten plunger to 33 Ft-Lbs. (45 Nm).

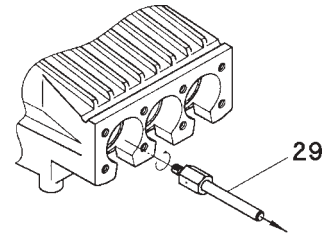

**Important!** Check the leakage bores  $\phi 4$  of the seal sleeves (36) and seal cases (46) for dirt and clean if necessary. The elbow screw-in joints (37B) and elbow pipes (37A) must also be checked for dirt and cleaned if necessary.

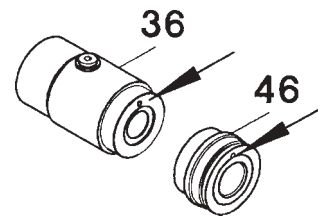

**Important!** The  $\phi 4$  leakage bore of the middle seal sleeve must be closed by a rubber plug (36A) to ensure water circulation from seal sleeve 1 to seal sleeve 3.

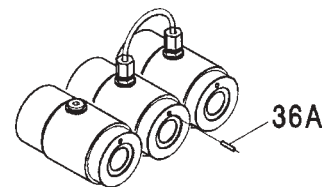

Fit the drip-return unit (32/33/35), the high-pressure seal unit (38, 39, 40) and tension spring (41) into the seal sleeve. Then push the assembled seal sleeves (36) carefully on to the plungers and into the drive; thereafter mount elbow pipes (37A) as per the exploded view and tighten the screw-in joints (37B) carefully. Check O-rings on the drip-return ring (45) as well as border seal ring (43) and replace where necessary. Push the valve casing (54) with its seal cases (46) and drip-return rings (44) onto the seal sleeves (36). Tighten valve casing nuts (59) evenly to 59 Ft-Lbs. (80 Nm).

### To Dismantle Gear

Disassemble valve casing and seal sleeves firstly; then screw out oil plug (12) and drain oil. Thereafter screw off gear cover (4) and bearing cover (14).

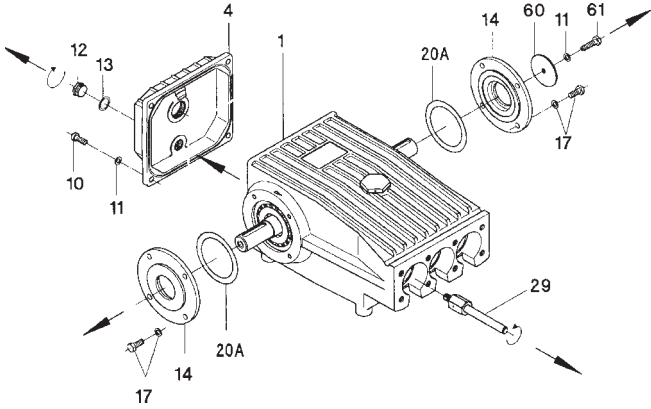

Remove connecting rod (connecting rod) screws, and push the front of the connecting rod parts forward as far as possible into the crosshead guide.

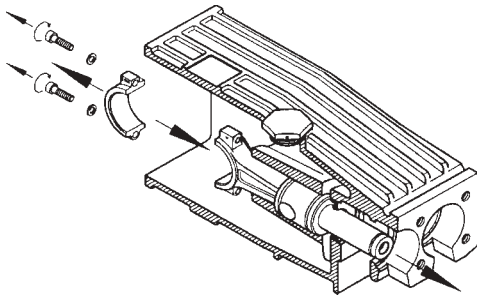

**Important!** Connecting rods are marked for identification. Do not twist connecting rod halves. When reassembling, connecting rods are to be fitted back onto the shaft journals in their exact original position.

Turning the crankshaft gently, tap it out carefully to one side using a rubber hammer.

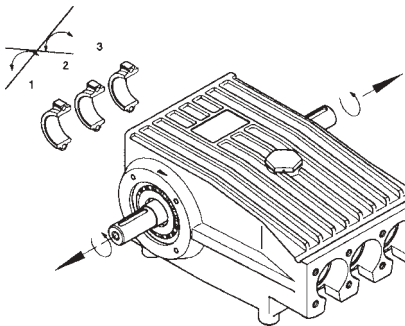

**Important!** Do not bend connecting rod shafts. Check the running surface of the shaft and connecting rods as well as the shaft seal rings and tapered roller bearings.

### To Reassemble

Using a soft tool, press in outer bearing ring on one side of the crankcase until its outer edge sits evenly on the bearing bore. Then screw on bearing cover together with shaft seal ring and O-ring. Insert shaft through the bearing hole on the opposite side. Press in outer bearing ring and tension inwards with bearing cover, keeping the shaft in vertical position and turning it slowly so that the tapered rollers of the bearing sit evenly on the outer bearing ring. Adjust axial bearing clearance to at least 0.1mm and maximum 0.15mm by placing fitting discs (20A) under one of the bearing covers.

**Important!** After assembly has been completed, the shaft should turn easily with very little clearance. Tighten connecting rod screws to 26 Ft-Lbs. (35 Nm).

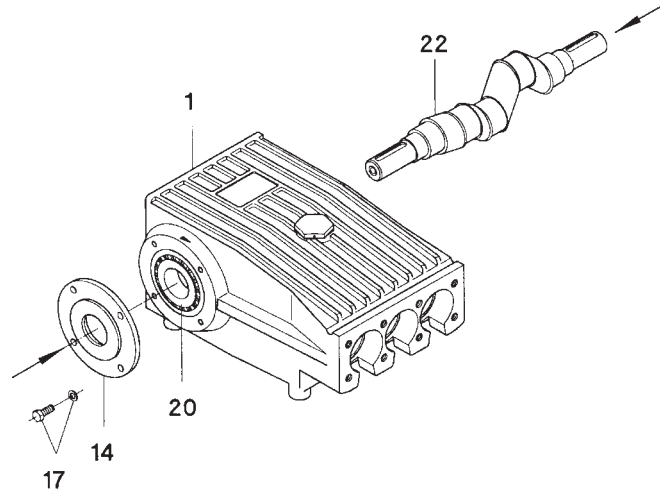

# Specifications Model LP8000

	U.S. ....	Metric
Volume .....	4.6 GPM .....	17.5 LPM
Discharge Pressure .....	11,600 PSI .....	800 BAR
Speed .....		1000 RPM
Inlet Pressure .....	36 to 145 PSI .....	2.5 to 10 BAR
Plunger Diameter .....	0.55" .....	14mm
Plunger Stroke .....	1.65" .....	42mm
Crankshaft Diameter .....	1.38" .....	35mm
Key Width .....	0.38" .....	10mm
Crankshaft Mounting .....		Either side
Shaft Rotation .....	Top of pulley towards manifold	
Temperature of Pumped Fluids .....	Up to 104 °F .....	40 °C
Inlet Ports .....		(2) 1/2" BSP
Discharge Ports .....		(2) 1/2" BSP
Weight .....	115 lbs. ....	52 kg
Crankcase Oil Capacity .....	0.92 Gal. ....	3.5 Liters
Fluid End Material .....	Stainless Steel	

Consult the factory for special requirements that must be met if the pump is to operate beyond one or more of the limits specified above.

**HORSEPOWER RATINGS:**

The rating shown are the power requirements for the pump. Gas engine power outputs must be approximately twice the pump power requirements shown above.

We recommend a 1.15 service factor be specified when selecting an electric motor as the power source. To compute specific pump horsepower requirements, use the following formula:

$$HP = (GPM \times PSI) / 1450$$

<b>LP800 HORSEPOWER CHART</b>					
RPM	GPM	5000 PSI	7250 PSI	10,000 PSI	11,600 PSI
600	2.8	9.9	14.3	19.7	22.9
700	3.2	11.5	16.7	23.0	26.7
800	3.7	13.1	19.1	26.3	30.5
900	4.1	14.8	21.4	29.6	34.3
1000	4.6	16.4	23.8	32.9	38.1

# Specifications Model LP1000

	U.S. ....	Metric
Volume .....	3.4 GPM .....	12.8 LPM
Discharge Pressure .....	15000 PSI .....	1000 BAR
Speed .....		1000 RPM
Inlet Pressure .....	36 to 145 PSI .....	2.5 to 10 BAR
Plunger Diameter .....	0.47" .....	12mm
Plunger Stroke .....	1.65" .....	42mm
Crankshaft Diameter .....	1.38" .....	35mm
Key Width .....	0.38" .....	10mm
Crankshaft Mounting .....		Either side
Shaft Rotation .....	Top of pulley towards manifold	
Temperature of Pumped Fluids .....	Up to 104 °F .....	40 °C
Inlet Ports .....		(2) 1/2" BSP
Discharge Ports .....		(2) 1/2" BSP
Weight .....	115 lbs. ....	52 kg
Crankcase Oil Capacity .....	0.92 Gal. ....	3.5 Liters
Fluid End Material .....	Stainless Steel	

Consult the factory for special requirements that must be met if the pump is to operate beyond one or more of the limits specified above.

**HORSEPOWER RATINGS:**

The rating shown are the power requirements for the pump. Gas engine power outputs must be approximately twice the pump power requirements shown above.

We recommend a 1.15 service factor be specified when selecting an electric motor as the power source. To compute specific pump horsepower requirements, use the following formula:

$$HP = (GPM \times PSI) / 1450$$

<b>LP1000 HORSEPOWER CHART</b>					
RPM	GPM	7250 PSI	10,000 PSI	12,250 PSI	15,000 PSI
600	2.0	10.6	14.6	17.9	21.9
700	2.4	12.3	17.0	20.8	25.5
800	2.7	14.1	19.4	23.8	29.1
900	3.1	15.8	21.9	26.8	32.8
1000	3.4	17.6	24.3	29.8	36.4

# Models LP800/1000 - Exploded View

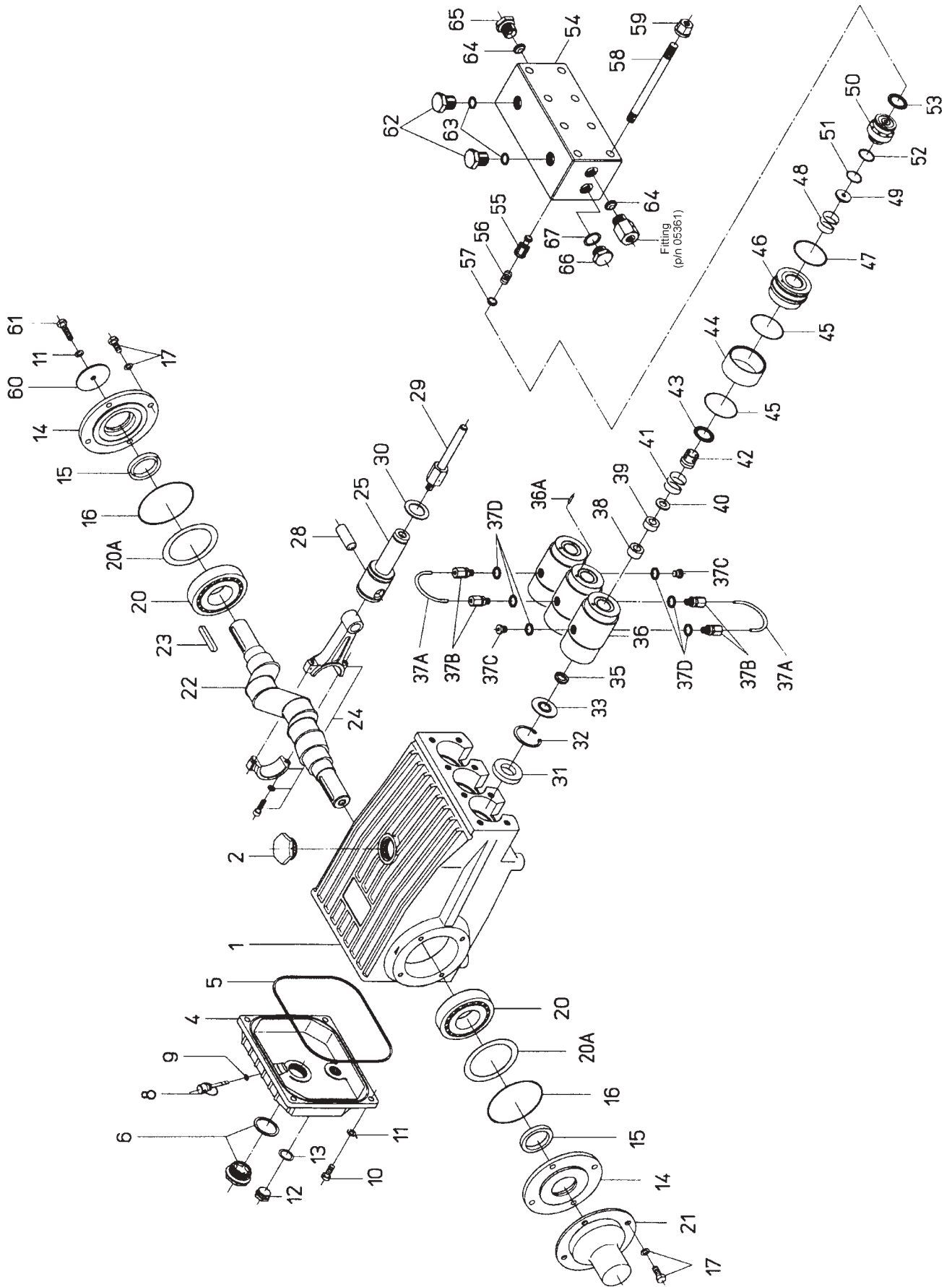

## LP800 and LP1000 Spare Parts List

ITEM #	PART #	DESCRIPTION	QTY	ITEM #	PART #	DESCRIPTION	QTY
1	07759	Crankcase	1	37B	06588	Screw-in Pipe Connection	4
2	13000	Oil Filler Plug Assy.	1	37C	06589	Plug G 1/8" c/w Hexagon	2
4	06085	Crankcase Cover	1	37D	07204-0100	Steel Washer	6
5	07104	O-Ring for Cover	1	38	05366	Sleeve Support Ring, LP800	3
6	07186	Oil Sight Glass	1	38	06590	Sleeve Support Ring, LP1000	3
8	06086	Oil Dipstick Assy	1	39	05367	Spiral Ring, LP800	3
9	01009	O-Ring for Oil Dipstick	1	39	06591	Spiral Ring, LP1000	3
10	01010	Cylinder Screw	4	40	05368	Support Ring, LP800	3
11	01011-0400	Spring Ring	5	40	06592	Support Ring, LP1000	3
12	07109	Plug, 1/2 BSP"	1	41	05369	Seal Tension Spring, LP800	3
13	07182	Gasket	1	41	06593	Seal Tension Spring, LP1000	3
14	07111	Bearing Cover	2	42	06594	Spring Tension Ring	3
15	07112	Radial Shaft Seal	2	43	06595	Border Seal Ring	3
16	07113	O-Ring for Bearing Cover	2	44	06596	Drip-Return Ring	3
17	07114	Hexagon Screw	8	45	06560	O-Ring	6
20	07116	Taper Roller Bearing	2	46	06597	Seal Case	3
20A	07117	Fitting Disc	1-3	47	07740	O-Ring	3
20B	13001	Fitting Disc	1-3	48	07750	Valve Spring	3
21	07118	Shaft Protector	1	49	06598	Inlet Valve Plate	3
22	13242	Crankshaft	1	50	06599	Valve Body	3
23	13243	Fitting Key	1	51	12092	O-Ring	3
24	13340	Connecting Rod Assy	3	52	06600	Support Ring for item #51	3
25	13341	Crosshead/Plunger Assy	3	53	06601	Border Seal Ring	3
28	13232	Crosshead Pin	3	54	06602	Valve Casing	1
29	05363	Plunger Assembly, LP800	3	55	06603	Spring Guide	3
29	06583	Plunger Assembly, LP1000	3	56	12090	Valve Spring	3
30	07779	Oil Scraper	3	57	06604	Discharge Valve Plate	3
31	07133	Radial Shaft Seal	3	58	06605	Stud Bolt	8
32	06584	Clip Ring	3	59	13430	Hexagon Screw	8
33	05384	Support Disc, LP800	3	60	13020	Disc for Crankshaft	1
33	06610	Support Disc, LP1000	3	61	06602	Hexagon Nut	1
35	06483	Grooved Ring, LP800	3	62	05371	Plug, 1/2" BSP	2
35	08598	Grooved Ring, LP1000	3	63	12323	Copper Ring	2
36	05385	Seal Sleeve, LP800	3	64	05372	Seal Cone	2
36	06585	Seal Sleeve, LP1000	3	65	05373	Plug, Discharge, 1/2" BSP	1
36A	06586	Plug	1	66	07109	Plug, Inlet, 1/2" BSP	1
37A	06587	Elbow for Rinsing Pipe	2	67	07182	Copper Ring	1

## LP800 and LP1000 Kits

### Seal Repair Kit - LP1000 - #09517

Item	Part #	Description	Qty
35	08598	Grooved Ring	3
38	06590	Sleeve Support Ring	3
39	06591	Spiral Ring	3
43	06595	Border Seal Ring	3
45	06560	O-Ring	6
47	07740	O-Ring	3

### Seal Repair Kit - LP800 - #09618

Item	Part #	Description	Qty
35	06483	Grooved Ring	3
38	05366	Sleeve Support Ring	3
39	05367	Spiral Ring	3
43	06595	Border Seal Ring	3
45	06560	O-Ring	6
47	07740	O-Ring	3

### Valve Repair Kit - #09518

Item	Part #	Description	Qty
48	07750	Valve Spring	3
49	06598	Inlet Valve Plate	3
50	06599	Valve Body	3
51	12092	O-Ring	3
52	06600	Support Ring for O-Ring	3
53	06601	Border Seal Ring	3
55	06603	Sping Guide	3
56	12090	Valve Spring	3
57	06604	Discharge Valve Plate	3

## LP800 and LP1000 Torque Specifications

Position	Item#	Description	Torque Amount
24	13340	Connecting Rod Assy.	26 ft.-lbs. (35 NM)
29	05363/06583	Plunger Assembly	33 ft.-lbs. (45 NM)
59	06602	Hexagon Nut	59 ft.-lbs. (80 NM)

## LP800 and LP1000 Dimensions - Inches - (mm)

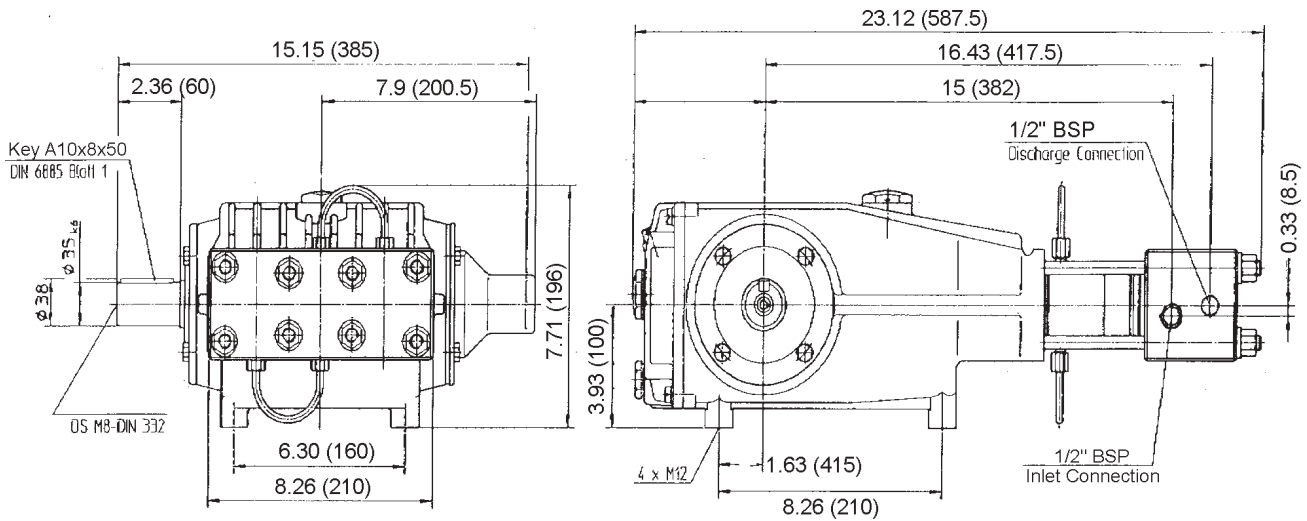

### GIANT INDUSTRIES LIMITED WARRANTY

Giant Industries, Inc. pumps and accessories are warranted by the manufacturer to be free from defects in workmanship and material as follows:

1. For portable pressure washers and self-service car wash applications, the discharge manifolds will never fail, period. If they ever fail, we will replace them free of charge. Our other pump parts, used in portable pressure washers and in car wash applications, are warranted for five years from the date of shipment for all pumps used in NON-SALINE, clean water applications.
2. One (1) year from the date of shipment for all other Giant industrial and consumer pumps.
3. Six (6) months from the date of shipment for all rebuilt pumps.
4. Ninety (90) days from the date of shipment for all Giant accessories.

This warranty is limited to repair or replacement of pumps and accessories of which the manufacturer's evaluation shows were defective at the time of shipment by the manufacturer. The following items are NOT covered or will void the warranty:

1. Defects caused by negligence or fault of the buyer or third party.
2. Normal wear and tear to standard wear parts.
3. Use of repair parts other than those manufactured or authorized by Giant.
4. Improper use of the product as a component part.
5. Changes or modifications made by the customer or third party.
6. The operation of pumps and or accessories exceeding the specifications set forth in the Operations Manuals provided by Giant Industries, Inc.

Liability under this warranty is on all non-wear parts and limited to the replacement or repair of those products returned freight prepaid to Giant Industries which are deemed to be defective due to workmanship or failure of material. A Returned Goods Authorization (R.G.A.) number and completed warranty evaluation form is required prior to the return to Giant Industries of all products under warranty consideration. Call (419)-531-4600 or fax (419)-531-6836 to obtain an R.G.A. number.

Repair or replacement of defective products as provided is the sole and exclusive remedy provided hereunder and the MANUFACTURER SHALL NOT BE LIABLE FOR FURTHER LOSS, DAMAGES, OR EXPENSES, INCLUDING INCIDENTAL AND CONSEQUENTIAL DAMAGES DIRECTLY OR INDIRECTLY ARISING FROM THE SALE OR USE OF THIS PRODUCT.

THE LIMITED WARRANTY SET FORTH HEREIN IS IN LIEU OF ALL OTHER WARRANTIES OR REPRESENTATION, EXPRESS OR IMPLIED, INCLUDING WITHOUT LIMITATION ANY WARRANTIES OR MERCHANTABILITY OR FITNESS FOR A PARTICULAR PURPOSE AND ALL SUCH WARRANTIES ARE HEREBY DISCLAIMED AND EXCLUDED BY THE MANUFACTURER.



**GIANT INDUSTRIES, INC.**, 900 N. Westwood Avenue, P.O. Box 3187, Toledo, OH 43607  
 PHONE: (419) 531-4600, FAX: (419) 531-6836, www.giantpumps.com  
 © Copyright 2007 Giant Industries, Inc.