

Models

GP8045 / GP8048

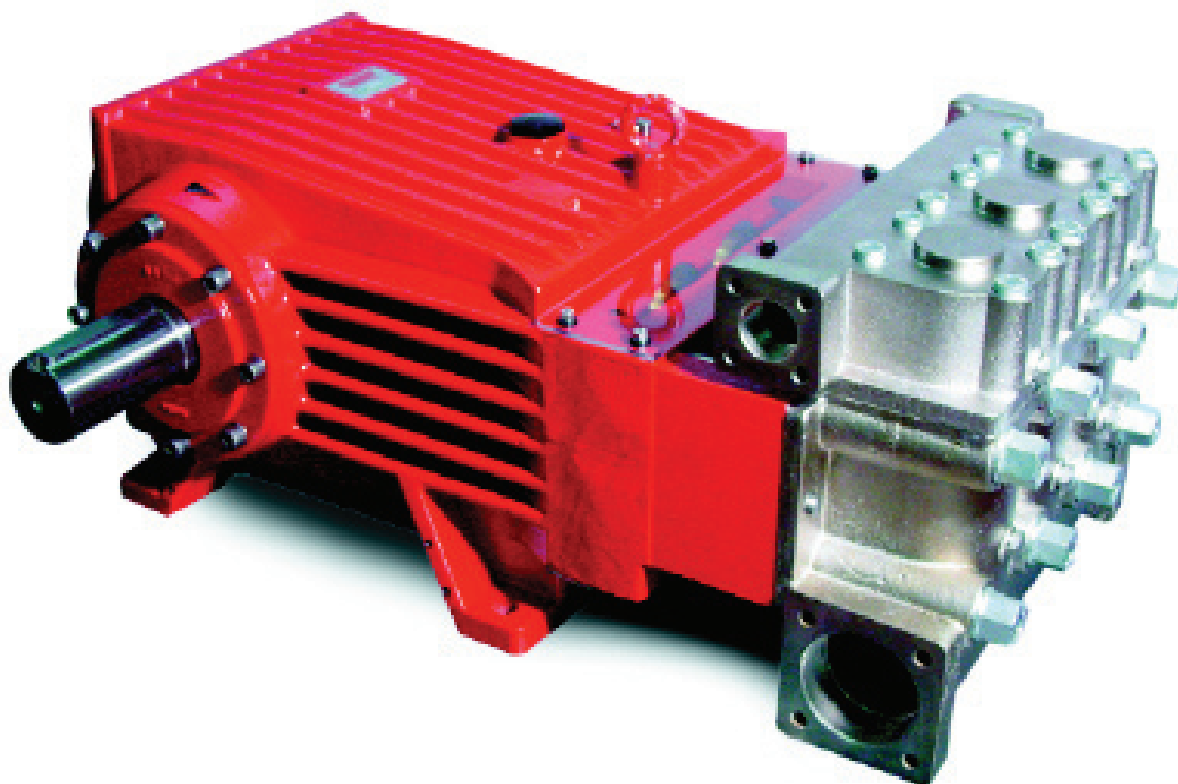

Contents:

Installation Instructions:	page 2
Pump Specifications (GP8045):	page 3
Exploded View	page 4
Parts List:	page 5
Pump Specifications (GP8048):	page 6
Repair Kits/Tool List/Torque Specifications	page 7
Troubleshooting Chart:	page 7
Repair Instructions:	pages 8-10
Dimensions:	page 11
Warranty Information	back page

INSTALLATION INSTRUCTIONS

Installation of the Giant Industries, Inc., pump is not a complicated procedure, but there are some basic steps common to all pumps. The following information is to be considered as a general outline for installation. If you have unique requirements, please contact Giant Industries, Inc. or your local distributor for assistance.

1. The pump should be installed flat on a base to a maximum of a 15 degree angle of inclination to ensure optimum lubrication.
2. The inlet to the pump should be sized for the flow rate of the pump with no unnecessary restrictions that can cause cavitation. Teflon tape should be used to seal all joints. If these pumps are to be operated at temperatures in excess of 86° F, it is important to insure a positive head to the pump to prevent cavitation.
3. The discharge plumbing from the pump should be properly sized to the flow rate to prevent line pressure loss to the work area. It is essential to provide a safety bypass valve between the pump and the work area to protect the pump from pressure spikes in the event of a blockage or the use of a shut-off gun.
4. Use of a dampener is necessary to minimize pulsation at drive elements, plumbing, connections, and other system areas. The use of a dampener with Giant Industries, Inc. pumps is optional, although recommended by Giant Industries, Inc. to further reduce system pulsation. Dampeners can also reduce the severity of pressure spikes that occur in

IMPORTANT OPERATING CONDITIONS

Failure to comply with any of these conditions invalidates the warranty

1. Prior to initial operation, add oil to crankcase so that oil level is between the two lines on the oil dipstick. DO NOT OVERFILL.
Use Industrial synthetic gear lube oil (ISO VG 220), such as Mobil Gear 630, Shell Oamala oil 220 or Texaco Meropa 220.
Crankcase oil should be changed after the first 50 hours of operation, then at regular intervals of 500 hours or less depending on operating conditions.
2. Pump operation must not exceed rated pressure, volume, or RPM. A pressure relief device must be installed in the discharge of the system.
3. Acids, alkalines, or abrasive fluids cannot be pumped unless approval in writing is obtained before operation from Giant Industries, Inc. Pump fluid should be filtered to 300 micron.

systems using a shut-off gun. A dampener must be positioned downstream from the unloader.

5. Crankshaft rotation on Giant Industries, Inc. pumps should be made in the direction designated by the arrows on the pump crankcase. Reverse rotation may be safely achieved by following a few guidelines available upon request from Giant Industries, Inc. Required horsepower for system operation can be obtained from the charts on pages 3 and 6.

6. Before beginning operation of your pumping system, remember: Check that the crankcase and seal areas have been properly lubricated per recommended schedules. Do not run the pump dry for extended periods of time. Cavitation will result in severe damage. Always remember to check that all plumbing valves are open and that pumped media can flow freely to the inlet of the pump.

Important! The service life of the seals is maximized if a minimal amount of leakage is present. A few drops of water can drip from each plunger every minute. Leakage has to be examined every day; the plunger seals must be changed should leakage become excessive (= constant dripping).

Finally, remember that high pressure operation in a pump system has many advantages. But, if it is used carelessly and without regard to its potential hazard, it can cause serious injury.

4. Run the pump dry approximately 10 seconds to drain the water before exposure to freezing temperatures.

5. **Important!** The pump and cooling system must be emptied if there is a danger of frost. Note that travel wind, for example, can cause water in pumps fitted on open vehicles to freeze even if the outside temperature is above freezing point.

To empty the cooling circuit, remove the L-joints (K11) on the pump head (50). Blow out the circuit liquid at the joint connection (K11/K7) using compressed air.

The torque tension on the valve casing nuts (49A) should be checked after approximately 200 operating hours. Please see page 8 for torque values.

Specifications Model GP8045

	U.S.	(Metric)
Volume.....	Up to 48.9 GPM ...	(185 LPM)
Discharge Pressure	Up to 4350 PSI	(300 bar)
Speed	Up to 580 RPM	580 RPM
Inlet Pressure.....	Up to 29 PSI	(2.0 bar)
Plunger Diameter.....	1.77".....	45mm
Plunger Stroke	2.83".....	72mm
Crankshaft Diameter.....	2.76".....	70mm
Key Width	0.55".....	14mm
Crankshaft Mounting.....		Either side
Shaft Rotation		Top of pulley towards manifold
Temperature of Pumped Fluids	Up to 86 °F	(30 °C)
Inlet Ports.....		(2) 3" BSP
Discharge Ports		(2) 1-1/4" BSP
Weight.....	705 lbs.	(320kg)
Crankcase Oil Capacity	3.3 Gal.	(12.5 liters)
Fluid End Material.....		Nickle plated Spheroidal Cast Iron

Consult the factory for special requirements that must be met if the pump is to operate beyond one or more of the limits specified above.

GP8045 HORSEPOWER REQUIREMENTS					
RPM	GPM	1000 PSI	2000 PSI	3000 PSI	4350 PSI
300	25.3	17.4	34.9	52.3	75.9
400	33.7	23.2	46.5	69.7	101.1
500	42.2	29.1	58.2	87.3	126.6
580	48.9	33.7	67.5	101.2	146.7

HORSEPOWER RATINGS:

The rating shown are the power requirements for the pump. Gas engine power outputs must be approximately twice the pump power requirements shown above.

We recommend a 1.15 service factor be specified when selecting an electric motor as the power source. To compute specific pump horsepower requirements, use the following formula:

$$\frac{\text{GPM} \times \text{PSI}}{1450} = \text{HP}$$

SPECIAL NOTE:
 The theoretical gallons per revolution (gal/rev) is 0.0843.
 To find specific outputs at various RPM, use the formula:

$\text{GPM} = 0.0843 \times \text{RPM}$

GP8045 / GP8048 Parts List

<u>Item</u>	<u>Part</u>	<u>Description</u>	<u>Qty</u>	<u>Item</u>	<u>Part</u>	<u>Description</u>	<u>Qty</u>
1	05380	Crankcase	1	43	05396	Support Ring (GP8045)	3
2	06893	Oil Filler Plug Assy	1	45	05279	Pressure Ring (GP8048)	3
5	22929	Copper Washer	2	45	07636	Pressure Ring (GP8045)	3
6	06273	Oil Drain Plug	1	49	05072	Stud Bolt	8
7	05381	Plug, Oil Dip Stick	1	49A	05073	Hexagon Nut	8
8	05035	Oil Dip Stick Ass'y	1	50	05397	Valve Casing	1
9	01009	O-Ring	1	50A	13162	Centering Stud	2
12	07109	Plug G-1/2	2	50B	05398	Discharge Casing	1
13	06272	Copper Ring	2	51	05399	Suction Valve Ass'y	3
14	05036	Bearing Cover Closed	1	51A	05407	Spring Tension Cap	3
14A	05298	Bearing Cover Open	1	51B	05400	Suction Valve Seat	3
15	05112	Radial Shaft Seal	1	51C	05314	Valve Plate	3
16	05037	O-ring	2	51D	05408	O-Ring	3
17	05038	Inner Hexagon Screw	16	51E	07732-0100	Valve Spring	3
18	05039	Spring Ring	16	51F	08282	Valve Spring Guide	3
21	05044	Tapered Roller Bearing	2	52	05406	Discharge Valve Ass'y.	3
21A	05042	Fitting Disc	1-5	52A	05407	Spring Tension Cap	3
21B	05043	Fitting Disc	1-5	52B	05641	Discharge Valve Seat	3
22	05299	Crankshaft	1	52C	05314	Valve Plate	3
23	05300	Fitting Key	1	52D	05408	O-Ring	6
24	05047	Conn-rod Assy	3	52E	07732-0100	Valve Spring	3
25	05048	Crosshead c/w Plunger	3	52F	08282	Valve Spring Guide	3
28	05049	Crosshead Pin	3	56	05409	Discharge Valve Adapter	3
29	05051	Hexagon Screw	4	56A	05408	O-Ring	3
29A	05382	Bracket 1 - Cooling Hose	2	57	07173	Tension Spring	6
29B	05383	Bracket 2 - Cooling Hose	2	58	05087	Hexagon Socket Screw	12
30	05052	Cover Plate	1	59	07109	Plug G-1/2	2
30A	07225-0100	Screw 316 S.S	5	59A	06272	Copper Gasket	2
30B	13136	Grommet	5	60	06909	Plug G 1-1/4	1
30C	08280	Washer	9	61	05088	Plug G-3	1
30D	05050	Splash Cover	1	62	05302	Plug G-1/4	6
31	07623	Eye Bolt	3	62A	06934	Copper Gasket	6
32	05058	Radial Shaft Seal	3	66	05303	Disc for Crankshaft	1
33A	05056	O-Ring	3	67	13433	Hexagon Screw	1
33B	05054	Clip Ring	3	78	05052	Oil Cooler	1
33C	05059	Fitting Disc	3	79	07662	Tool for Valve	1
34	05060	Oil Shield	3				
36B	05384	Plunger Pipe (GP8048)	3	K1	05026	Cooling Vane Plate	1
36B	05385	Plunger Pipe (GP8045)	3	K2	05027	Seal for Gear Cover	2
36C	05062	Tension Screw	3	K3	05028	Gear Cover	1
36D	07665	Copper Washer	3	K4	05029	Hexagon Head Countersunk Screw	8
36E	06900	Centering Sleeve	3				
38	05386	Seal Case	3	K5	07381	Hexagon Socket Screw	8
38A	05387	O-Ring	6	K6	08041	Washer	8
39	05388	Seal Case (GP8048)	3	K7	05030	Connection for Oil Cooler	1
39	05389	Seal Case (GP8045)	3	K8	06272	Copper Seal	6
39A	05066	O-Ring	3	K9	07109	Plug G1/2	2
40	05390	Seal Ring (GP8048)	3	K10	05031	Connecting Branch	3
40	13290	Seal Ring (GP8045)	3	K11	05032	U-Joint Connector w/Nut	3
41	05391	Pressure Ring (GP8048)	3	K12	05033	Tube for Cooler	2
41	05392	Pressure Ring (GP8045)	3	K13	05402	Hose Clamp	4
42	05393	Sleeve (GP8048)	9	K14	05403	Hose Guard	2
42	05394	Sleeve (GP8045)	9	K15	05404	Hose Coupling Nut	1
43	05395	Support Ring (GP8048)	3	K16	05405	Flat Gasket for Oil Cooler	4

Specifications Model GP8048

	U.S.	(Metric)
Volume.....	Up to 56.8 GPM ...	(215 LPM)
Discharge Pressure	Up to 3770 PSI	(260 bar)
Speed	Up to 580 RPM	580 RPM
Inlet Pressure.....	Up to 29 PSI	(2.0 bar)
Plunger Diameter.....	1.89".....	48mm
Plunger Stroke	2.83".....	72mm
Crankshaft Diameter.....	2.76".....	70mm
Key Width	0.55".....	14mm
Crankshaft Mounting.....		Either side
Shaft Rotation.....		Top of pulley towards manifold
Temperature of Pumped Fluids	Up to 86 °F	(30 °C)
Inlet Ports.....		(2) 3" BSP
Discharge Ports		(2) 1-1/4" BSP
Weight.....	705 lbs.	(320kg)
Crankcase Oil Capacity	3.3 Gal.	(12.5 liters)
Fluid End Material.....		Nickle plated Spheroidal Cast Iron

Consult the factory for special requirements that must be met if the pump is to operate beyond one or more of the limits specified above.

GP8048 HORSEPOWER REQUIREMENTS					
RPM	GPM	1000 PSI	2000 PSI	3000 PSI	3770 PSI
300	29.4	20.3	40.6	60.8	76.4
400	39.2	27.0	54.1	81.1	101.9
500	49.0	33.8	67.6	101.4	127.4
580	56.8	39.2	78.3	117.5	147.7

HORSEPOWER RATINGS:
The rating shown are the power requirements for the pump. Gas engine power outputs must be approximately twice the pump power requirements shown above.

We recommend a 1.15 service factor be specified when selecting an electric motor as the power source. To compute specific pump horsepower requirements, use the following formula:

$$\frac{\text{GPM} \times \text{PSI}}{1450} = \text{HP}$$

SPECIAL NOTE:
The theoretical gallons per revolution (gal/rev) is 0.0979. To find specific outputs at various RPM, use the formula:

$$\text{GPM} = 0.0979 \times \text{RPM}$$

GP8045/GP8048 PUMP REPAIR KITS

Plunger Packing Kits

GP8045 - #09626

Item	Part #	Description	Qty.
38A	05387	O-Ring	6
39A	05066	O-Ring	3
40	13290	Seal Ring	3
42	05394	V-Sleeve	9

GP8048 - #09627

Item	Part #	Description	Qty.
38A	05387	O-Ring	6
39A	05066	O-Ring	3
40	05390	Seal Ring	3
42	05393	V-Sleeve	9

Oil Seal Kit - #09584

Item	Part #	Description	Qty.
32	05058	Radial Shaft Seal	3
33A	05056	O-Ring	3

Valve Assembly Kit - GP8045 & GP8048

Inlet Valve Kit - #09628

Item	Part #	Description	Qty.
51B	05400	Inlet Valve Seat	3
51C	05314	Valve Plate	3
51D	05408	O-Ring	3
51E	07732-0100	Valve Spring	3
51F	08282	Valve Spring Guide	3
56A	05408	O-Ring	3

Discharge Valve Kit - #09629

Item	Part #	Description	Qty.
52B	05641	Discharge Valve Seat	3
52C	05314	Valve Plate	3
52D	05408	O-Ring	3
52E	07732-0100	Valve Spring	3
52F	08282	Valve Spring Guide	3
56A	05408	O-Ring	3

GP8045/GP8048 TOOL LIST AND TORQUE SPECIFICATIONS

ITEM	PART #	DESCRIPTION	TORQUE Ft-lbs (NM)	TOOL NEEDED
17	05038	Hexagon Socket Screw	64 (87)	10mm allen wrench
24	05047	Connecting Rod Hex Socket Screw	37 (50)	8mm allen wrench
33B	05054	Clip Ring	n/a	Industrial Snap ring pliers
36C	05062	Tension Screw	30 (40)	16mm socket
49A	05073	Hexagon Nut (manifold)	265 (360)	30mm socket
51/52	05399 / 05406	Valve Assemblies	n/a	Valve puller (p/n 07662) - included w/ pump
58	05087	Hexagon Socket Screw	132 (180)	12mm allen wrench
K5	07381	Hexagon Socket Screw	n/a	8mm allen wrench

GP8000 Trouble Shooting

Problem	Cause	Solution
Pressure drops, water leaks	V-sleeves leak	Replace V-sleeves, examine surface of plunger
Pressure drops, pump becomes loud	Discharge or suction valve leaks	Replace valve
	Steam formation (cavitation)	Reduce suction height, reduce flow resistance in inlet line, clean inlet filter, lower water temperature
Irregular pressure	Worn valves	Examine valves
	O-Ring on the valves or inlet valve adapter leaks	Examine O-ring, examine valve casing for unevenness on the sealing surfaces
Oil leaks at visible part of plunger	Gear sealing is leaky	Examine seals and running surface of plunger
Dirty mile-colored frothy oil	Oil has mixed with water	Replace oil immediately, find and fix the cause
Oil leakage on the crankshaft	Shaft seal ring leaks	Check seal and shaft
Noise increases without loss of pressure	Worn bearing	Dismantle gear, examine all parts, replace worn parts, check oil level. If service life was too short, check for excess strain or whether lubrication intervals were too long. Only specified lubricants are to be used

GP8045/GP8048 PUMP REPAIR INSTRUCTIONS

Valve Inspection and Repair

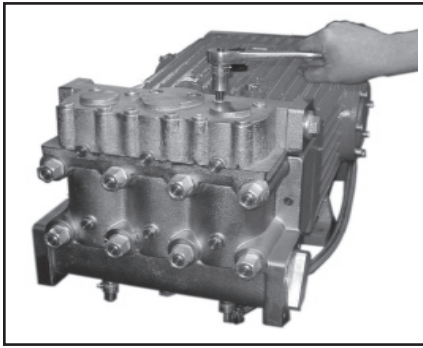

1) Remove bolts (58).

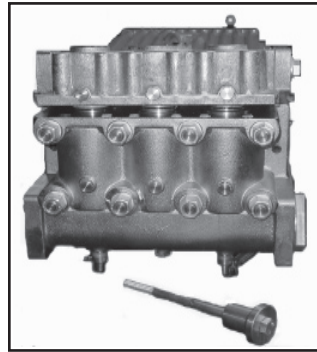

2) Remove discharge casing (50B) up and away.

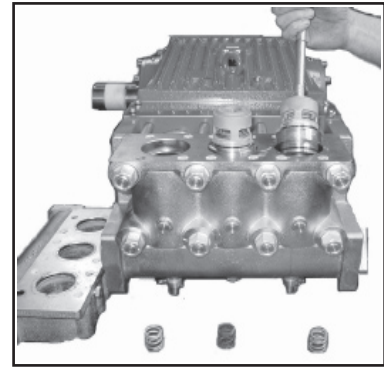

3) Take out pressure springs (57A). Pull out assembled valves (51 & 52) with fitting

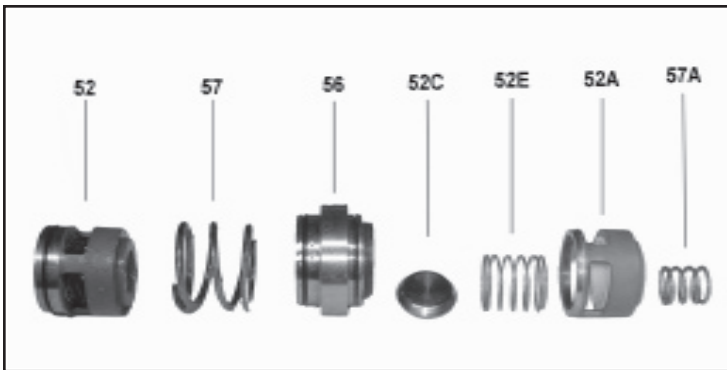

4) The spring tension cap (51A, 52A) is screwed together with the valve seat (51B or 52B). Screw off spring tension cap. Takeout springs (51E, 52E) and valve plate (51C, 52C). Check sealing surfaces and O-rings (51D, 52D). Replace worn parts. Coat threads of valve seat with silicon grease or molycote anti-seize Cu-7439 when reassembling. Before refitting the valves, clean the sealing surfaces in the casing and check for any damage. Tighten caps (58) at 133 Ft-lbs; check torque tension after 8-10 operating hours.

To Check Seals and Plunger Pipe

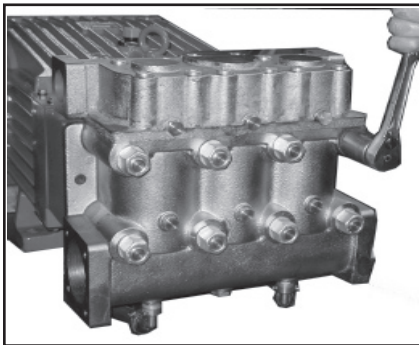

5) Remove hexagon nuts (49A) and valve casing together with seal case (38) from crankcase (1). If necessary, carefully tap the valve casing (50) past the centering stud (50A) using a rubber hammer.

IMPORTANT! If necessary, support the valve casing by resting it on wooden blocks or by using a pulley.

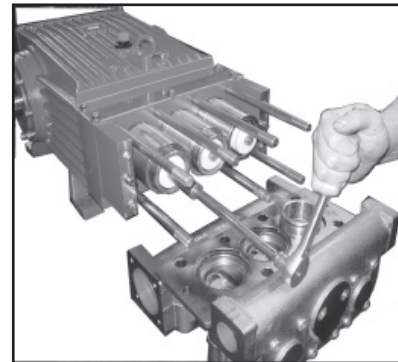

6) Remove tension screw (36C) and take seal sleeve (39) together with all mounted parts out of the drive. Pull plunger pipe out of the seal assembly and check for any damage. Carefully, remove seal rings (40) and sleeves (42) with a screw driver.

GP8045/GP8048 PUMP REPAIR INSTRUCTIONS

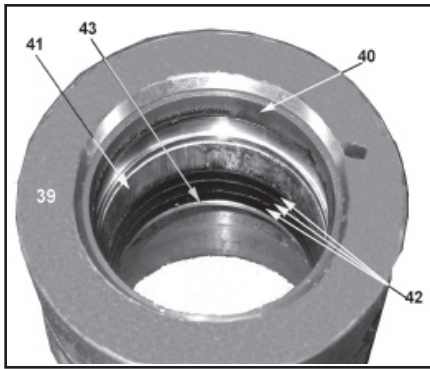

7) **Important!** Be careful not to damage the seal sleeve (39) and pressure ring (41). Check the inner diameter of the pressure ring for wear and if necessary replace together with seals (40) and (42). Clean all parts. New parts should be lightly coated with silicon grease before installation. Insert the seal unit (40, 41, 42 43) into the sleeve. Push the ceramic plunger carefully through the seals from the crankcase side. If necessary, the seals can be held tightly using a suitable pipe support held on the other side of the seal sleeve.

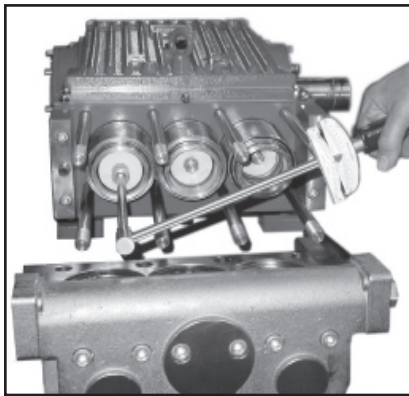

8) Coat the seal sleeve lightly with anti-corrosive grease (e.g. molycote no. Cu-7439) in its fitted area towards the crankcase. Insert the seal sleeves in to their crankcase fittings. Coat the threads of the tension screw (36C) lightly with thread glue and insert it together with a new copper ring (36D) through the ceramic pipe. Turn the pump per hand until the plunger (25) rests against the plunger pipe. Tighten the tension screw at 30 Ft.-lbs.

Important! Thread glue must never come between the plunger pipe (36B) and centering sleeve (36E). Overtensioning of the plunger pipe by excessive tightening of the tension screw and/or dirt or damage on the mounting surfaces can lead to plunger pipe breakage. Insert the seal tension spring (45) and O-ring (39A) in to the seal sleeve (39).

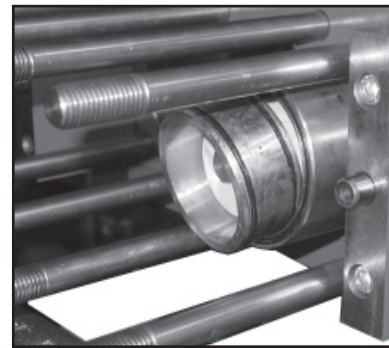

8) Take out the seal case (38) from the valve (if necessary secure 2 screwdrivers in the front O-ring groove to extract seal casing from valve casing). Coat seals with silicon grease before installing.

Important! Mounting surfaces of the crankcase and the valve casing must be clean and free of damage. The components must lie exactly and evenly on one another. The same exactness applies for all centering positions in the crankcase, pressure and valve casing.

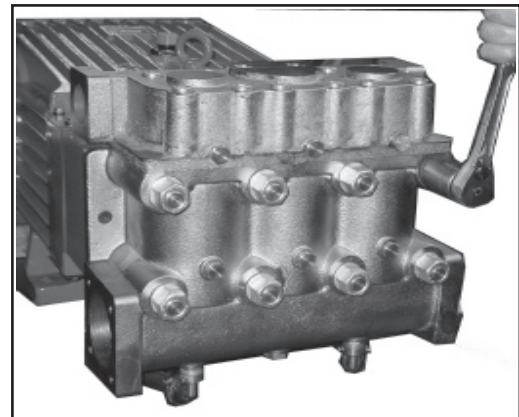

Replacing Valve Casing:

9) Put seal cases (38) in the centering holes of the valve casing, then push valve casing carefully on to centering studs (50A). Tighten hexagon screws (49A) evenly and crosswise at 266 Ft.-lbs.

Important! The torque tension on the screws (49A) must be checked after 8-10 operating hours; the pump must be at zero pressure. Thereafter, the tension is to be checked every 200 operating

GP8045/GP8048 PUMP REPAIR INSTRUCTIONS

To Dismantle Crankcase Gear

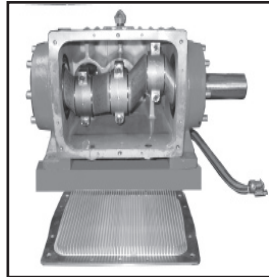
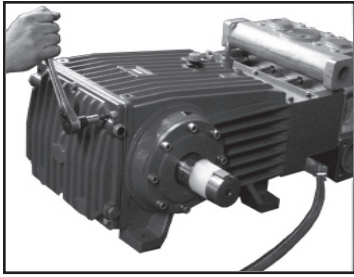

10) Take out plungers and seal sleeves as described above. Drain the oil by taking off the plug (12). After removing the clip ring (33B), lever out the seal retainer (33) with a screwdriver. Open hose adaptor (K11) and remove gear cover (K3). Remove the cooling vane plate (K1) by removing the screws (K4)

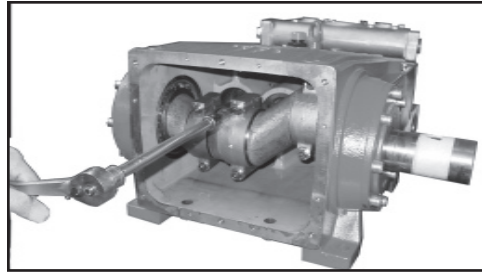

11) Remove the connecting rod screws (24).

Important! Connecting rods are marked 1 to 3 for identification. Do not twist connecting rod halves or interchange them. When reassembling, the connecting rod must be fitted in their exact original position on the crankshaft journals.

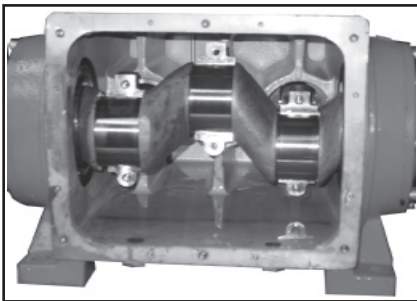

12) Push connecting rod halves together with the crosshead as far as possible into the crosshead guide. Take out bearing cover (14/14A) and push out crankshaft taking particular care that the con rod doesn't get bent. Check surfaces on the connecting rods (24), crankshaft (22) and crossheads (25). Check the surfaces of the crosshead guides in the crankcase for any unevenness.

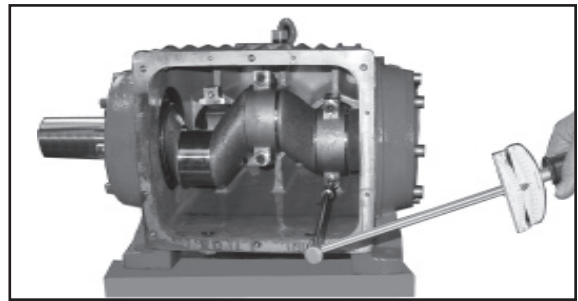

13) Reassemble in reverse order. Thread the long end of the crankshaft together with the inner bearing rings into the crankcase; then mount outer bearing ring (20) and spacer ring (22A). Mount connecting rod halves in their exact original position and tighten at 37 Ft-lbs.

Important! Connecting rods must be able to move slightly sideways on the stroke journals.

14) Mount bearing cover (14A) and tighten screws (17) to 64 Ft-lbs. Adjust axial play (clearance) on the crankshaft to minimum 0.1 mm / max. 0.15 mm using shims (21A/21B). The shaft should turn easily with little clearance. Connecting rod must sit exactly in the middle of each crank pin. Fit the bearing cover (14) and tighten the screws (17) at 64 Ft-lbs. Seal (32A) must always be installed so that the seal lip on the inside diameter faces the oil. Possible axial float of the seal adaptor (33) to be compensated with shims (33C).

Mount cooling plate (K1) and gear cover (K3) with their respective seals (K2). When assembling the cooling circuit line, make sure that the oil cooler connection (K7) is always joined to the upper connection (K3) of the gear cover.

GP8045, GP8048 -- DIMENSIONS (mm)

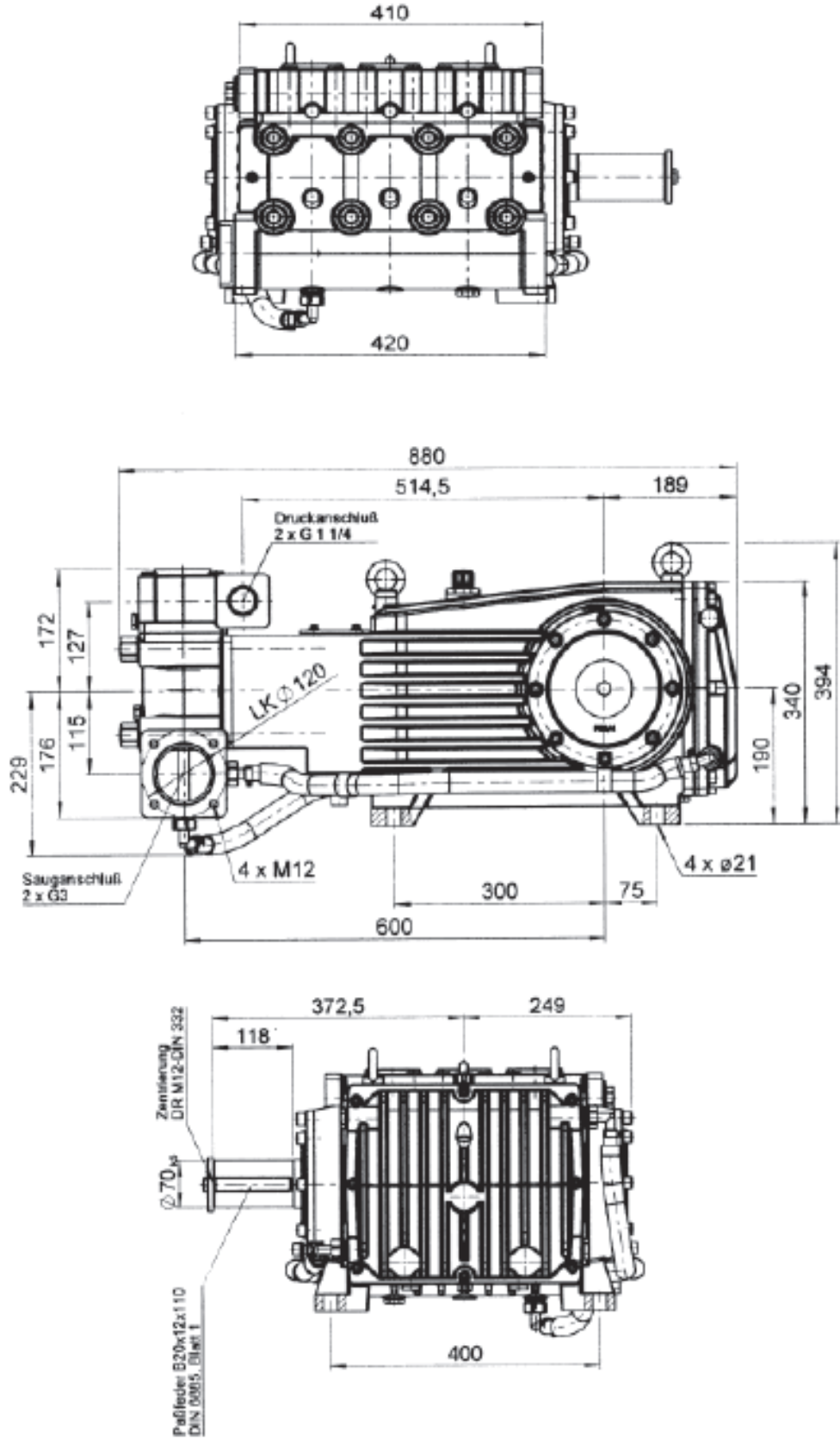

GIANT INDUSTRIES LIMITED WARRANTY

Giant Industries, Inc. pumps and accessories are warranted by the manufacturer to be free from defects in workmanship and material as follows:

1. For portable pressure washers and self-service car wash applications, the discharge manifolds will never fail, period. If they ever fail, we will replace them free of charge. Our other pump parts, used in portable pressure washers and in car wash applications, are warranted for five years from the date of shipment for all pumps used in NON-SALINE, clean water applications.
2. One (1) year from the date of shipment for all other Giant industrial and consumer pumps.
3. Six (6) months from the date of shipment for all rebuilt pumps.
4. Ninety (90) days from the date of shipment for all Giant accessories.

This warranty is limited to repair or replacement of pumps and accessories of which the manufacturer's evaluation shows were defective at the time of shipment by the manufacturer. The following items are NOT covered or will void the warranty:

1. Defects caused by negligence or fault of the buyer or third party.
2. Normal wear and tear to standard wear parts.
3. Use of repair parts other than those manufactured or authorized by Giant.
4. Improper use of the product as a component part.
5. Changes or modifications made by the customer or third party.
6. The operation of pumps and or accessories exceeding the specifications set forth in the Operations Manuals provided by Giant Industries, Inc.

Liability under this warranty is on all non-wear parts and limited to the replacement or repair of those products returned freight prepaid to Giant Industries which are deemed to be defective due to workmanship or failure of material. A Returned Goods Authorization (R.G.A.) number and completed warranty evaluation form is required prior to the return to Giant Industries of all products under warranty consideration. Call (419)-531-4600 or fax (419)-531-6836 to obtain an R.G.A. number.

Repair or replacement of defective products as provided is the sole and exclusive remedy provided hereunder and the MANUFACTURER SHALL NOT BE LIABLE FOR FURTHER LOSS, DAMAGES, OR EXPENSES, INCLUDING INCIDENTAL AND CONSEQUENTIAL DAMAGES DIRECTLY OR INDIRECTLY ARISING FROM THE SALE OR USE OF THIS PRODUCT.

THE LIMITED WARRANTY SET FORTH HEREIN IS IN LIEU OF ALL OTHER WARRANTIES OR REPRESENTATION, EXPRESS OR IMPLIED, INCLUDING WITHOUT LIMITATION ANY WARRANTIES OR MERCHANTABILITY OR FITNESS FOR A PARTICULAR PURPOSE AND ALL SUCH WARRANTIES ARE HEREBY DISCLAIMED AND EXCLUDED BY THE MANUFACTURER.



GIANT INDUSTRIES, INC.

900 N. Westwood Ave.

Toledo, Ohio 43607

(419) 531-4600

FAX (419) 531-6836

www.giantpumps.com

© Copyright 2010 Giant Industries, Inc.