

# Models GP7145 and GP7255A

---

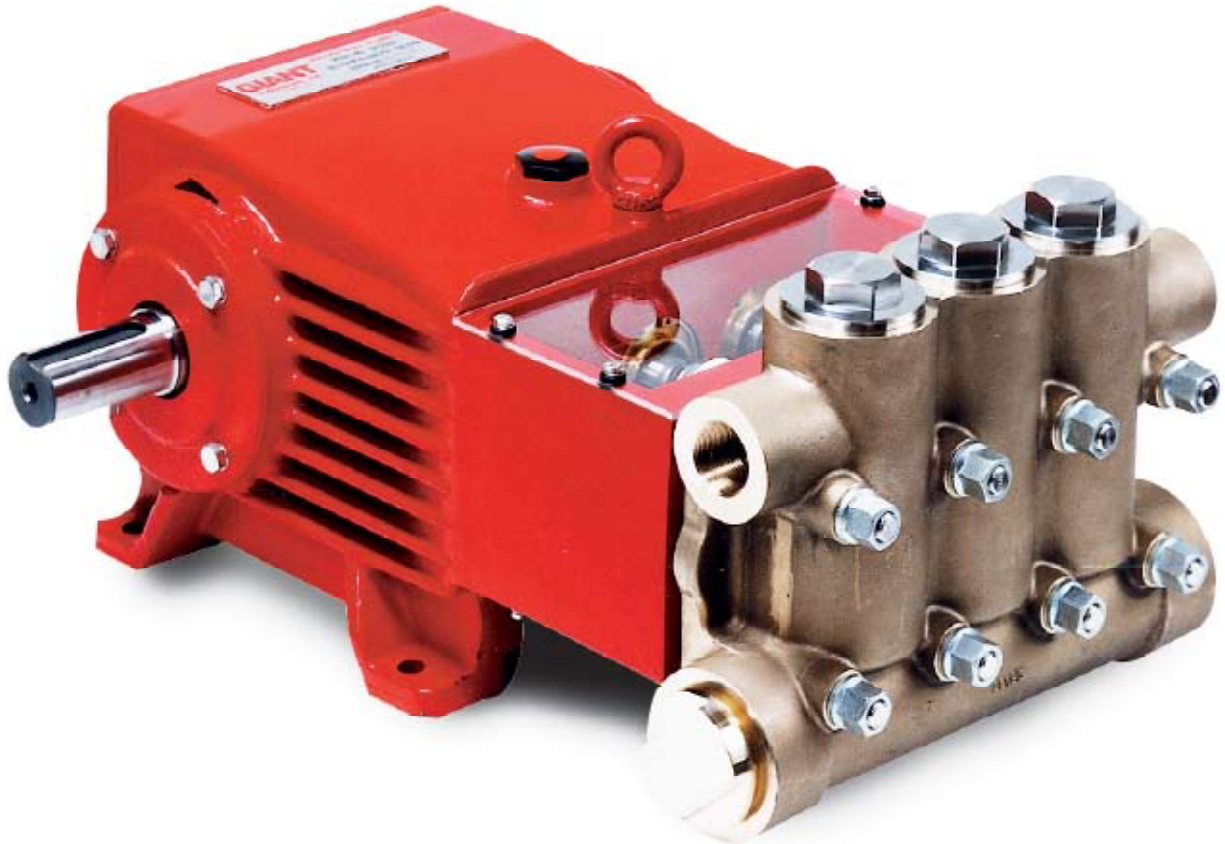

---

**GIANT**

Updated 5/10

**Contents:**

Installation Instructions	page 2 & 3
Pump Specifications (GP7145):	page 4
Pump Specifications (GP7255A):	page 5
Exploded View:	page 6
Parts List:	page 7
Kits/Torque Specifications:	page 8
Maintenance Information:	page 8
Repair Instructions:	page 9
Troubleshooting Guide:	page 10
Dimensions:	page 11
Warranty Information	back page

# INSTALLATION INSTRUCTIONS

**Installation of the Giant Industries, Inc., pump is not a complicated procedure, but there are some basic steps common to all pumps. The following information is to be considered as a general outline for installation. If you have unique requirements, please contact Giant Industries, Inc. or your local distributor for assistance.**

1. The pump should be installed flat on a base to a maximum of a 15 degree angle of inclination to ensure optimum lubrication.

**IMPORTANT** : If mounted on a vehicle with the possibility of unlevelness and/or the pump speed is between 300 and 500 RPM, the volume of oil should be 1.9 Gal.(7.3 liters). To check, put the oil dipstick in the bore situated next to the eye bolt (31).

2. The inlet to the pump should be sized for the flow rate of the pump with no unnecessary restrictions that can cause cavitation. Teflon tape should be used to seal all joints. If pumps are to be operated at temperatures in excess of 140° F, it is important to insure a positive head to the pump to prevent cavitation.

3. The discharge plumbing from the pump should be properly sized to the flow rate to prevent line pressure loss to the work area. It is essential to provide a safety bypass valve between the pump and the work area to protect the pump from pressure spikes in the event of a blockage or the use of a shut-off gun.

4. Use of a dampener is necessary to minimize pulsation at drive elements, plumbing, connections, and other system areas. The use of a dampener with Giant Industries, Inc. pumps is optional, although recommended by Giant Industries, Inc. to further reduce system pulsation. Dampeners can also reduce the severity of pressure spikes that occur in systems using a shut-off gun. A dampener must be positioned downstream from the unloader.

5. Crankshaft rotation on Giant Industries, Inc. pumps should be made in the direction designated by the arrows on the pump crankcase.

Reverse rotation may be safely achieved by following a few guidelines available upon request from Giant Industries, Inc. Required horsepower for system operation can be obtained from the charts on pages 4 and 5. During operation, all rotating parts, shaft(s) and coupling, must be covered with a protective guard. Plunger area must have the cover plate (30) secured in place. Do not step on or place weight on the plate (30).

6. Before beginning operation of your pumping system, remember: Check that the crankcase and seal areas have been properly lubricated per recommended schedules. Do not run the pump dry for extended periods of time. Cavitation will result in severe damage. Always remember to check that all plumbing valves are open and that pumped media can flow freely to the inlet of the pump.

**IMPORTANT:** The service life of the seals is maximized if a small amount of leakage occurs (a few drops per minute from each plunger). Leakage must be checked every day. If leakage becomes a constant dripping, the plunger seals must be changed.

Finally, remember that high pressure operation in a pump system has many advantages. But, if it is used carelessly and without regard to its potential hazard, it can cause serious injury.

**NOTE: Contact Giant Industries for Service School Information. Phone: (419)-531-4600.**

**IMPORTANT OPERATING CONDITIONS**

**Failure to comply with any of these conditions invalidates the warranty**

1. Prior to initial operation, add oil to crankcase so that oil level is between the two lines on the oil dipstick. **DO NOT OVERFILL.**

**Use Giant Recommended Oil**

P/N 01154, or the equivalent to  
SAE 85-90W Industrial Gear Lube.

Crankcase oil should be changed after the first 50 hours of operation, then at regular intervals of 500 hours or less depending on operating conditions.

**IMPORTANT:** When operating in high humidity or wide temperature fluctuations, oil must be changed if condensate or frothy oil occurs in crankcase.

2. Pump operation must not exceed rated pressure, volume, or RPM. A pressure relief device must be installed in the discharge of the system.

3. Acids, alkalines, or abrasive fluids cannot be pumped unless approval in writing is obtained before operation from Giant Industries, Inc.

4. Run the pump dry approximately 10 seconds to drain the water before exposure to freezing temperatures.

# Specifications Model GP7145

	U.S. ....	(Metric)
Volume (Continuous).....	47.5 GPM .....	(180 LPM)
Volume (Intermittent).....	60 GPM* .....	(227 LPM)*
Discharge Pressure .....	3000 PSI* .....	(207 bar)*
Speed (Continuous).....		750 RPM
Speed (Intermittent).....		947 RPM*
Inlet Pressure (maximum) .....	145 PSI .....	(10 bar)
Plunger Diameter.....	1.77" .....	45mm
Plunger Stroke.....	2.0" .....	52mm
Crankshaft Diameter.....	1.9" .....	48mm
Key Width .....	0.6" .....	14mm
Crankshaft Mounting .....		Either side
Shaft Rotation.....	Top of pulley towards manifold	
Temperature of Pumped Fluids.....	Up to 140°F .....	(60°C)
Inlet Ports .....		(2) 2-1/2" NPT
Discharge Ports .....		(2) 1-1/4" NPT
Weight .....	374 lbs. ....	(170 kg)
Crankcase Oil Capacity .....	1.6 Gal. ....	(6.0 liter)
Fluid End Material.....		Spheroidal Cast

Consult the factory for special requirements that must be met if the pump is to operate beyond one or more of the limits specified above.

### PULLEY INFORMATION

Pulley selection and pump speed are based on a 1725 RPM motor and "B" section belts. When selecting desired GPM, allow for a ±5% tolerance on pumps output due to variations in pulleys, belts and motors among manufacturers.

1. Select GPM required, then select appropriate motor and pump pulley from the same line.
2. The desired pressure is achieved by selecting the correct nozzle size that corresponds with the pump GPM.

### HORSEPOWER INFORMATION

Horsepower ratings shown are the power requirements for the pump. Gas engine power outputs must be approximately twice the pump power requirements shown above.

We recommend that a 1.15 service factor be specified when selecting an electric motor as the power source. To compute specific pump horsepower requirements, use the following formula:

$$(GPM \times PSI) / 1450 = HP$$

<b>GP7145 PULLEY SELECTION &amp; HORSEPOWER REQUIREMENTS</b>						
RPM	GPM	800 PSI	1000 PSI	1500 PSI	2000 PSI	3000 PSI*
300	19.0	10.5	13.1	19.7	26.2	39.3
400	25.3	14.0	17.4	26.2	34.9	52.3
500	31.7	17.5	21.9	32.8	43.7	65.6
600	38.0	21.0	26.2	39.3	52.4	78.6
750	47.5	26.2	32.8	49.1	65.5	98.3
789	50.0	27.6	34.5	51.7	69.0	103.4
947*	60.0	33.1	41.4	62.1	82.8	124.1

\* Intermittent Duty Only!

# Specifications

## Model GP7255A

	U.S. ....	(Metric)
Volume (Continuous).....	65.8 GPM	(250 LPM)
Volume (Intermittent).....	80 GPM*	(303 LPM)*
Discharge Pressure (Continuous) .....	1500 PSI	(100 bar)
Discharge Pressure (Intermittent).....	2000 PSI*	(140 bar)*
Speed (Continuous).....		700 RPM
Speed (Intermittent).....		851 RPM*
Inlet Pressure (maximum) .....	145 PSI	(10 bar)
Plunger Diameter.....	2.17"	55mm
Plunger Stroke.....	2.0"	52mm
Crankshaft Diameter.....	1.9"	48mm
Key Width .....	0.6"	14mm
Crankshaft Mounting .....		Either side
Shaft Rotation.....	Top of pulley towards manifold	
Temperature of Pumped Fluids.....	Up to 140 °F	(60 °C)
Inlet Ports .....	(2) 2-1/2" NPT	
Discharge Ports.....	(2) 1-1/4" NPT	
Weight .....	374 lbs.	(170 kg)
Crankcase Oil Capacity.....	1.6 Gal.	(6.0 liter)
Fluid End Material.....	Spheroidal Cast	

Consult the factory for special requirements that must be met if the pump is to operate beyond one or more of the limits specified above.

### PULLEY INFORMATION

Pulley selection and pump speed are based on a 1725 RPM motor and "B" section belts. When selecting desired GPM, allow for a ±5% tolerance on pumps output due to variations in pulleys, belts and motors among manufacturers.

1. Select GPM required, then select appropriate motor and pump pulley from the same line.
2. The desired pressure is achieved by selecting the correct nozzle size that corresponds with the pump GPM.

### HORSEPOWER INFORMATION

Horsepower ratings shown are the power requirements for the pump. Gas engine power outputs must be approximately twice the pump power requirements shown above.

We recommend that a 1.15 service factor be specified when selecting an electric motor as the power source. To compute specific pump horsepower requirements, use the following formula:

$$(GPM \times PSI) / 1450 = HP$$

GP7255A PULLEY SELECTION & HORSEPOWER REQUIREMENTS						
RPM	GPM	800 PSI	1000 PSI	1300 PSI	1500 PSI	2000 PSI*
479	45.0	24.8	31.0	40.3	46.6	62.1
531	49.9	27.5	34.4	44.7	51.6	68.8
585	55.0	30.3	37.9	49.3	56.9	75.9
638	60.0	33.1	41.4	53.8	62.1	82.8
700	65.8	36.3	45.4	59.0	68.1	90.8
851*	80.0	44.1	55.2	71.7	82.8	110.3*

\* Intermittent Duty Only!

# Exploded View - GP7145 and GP7255A

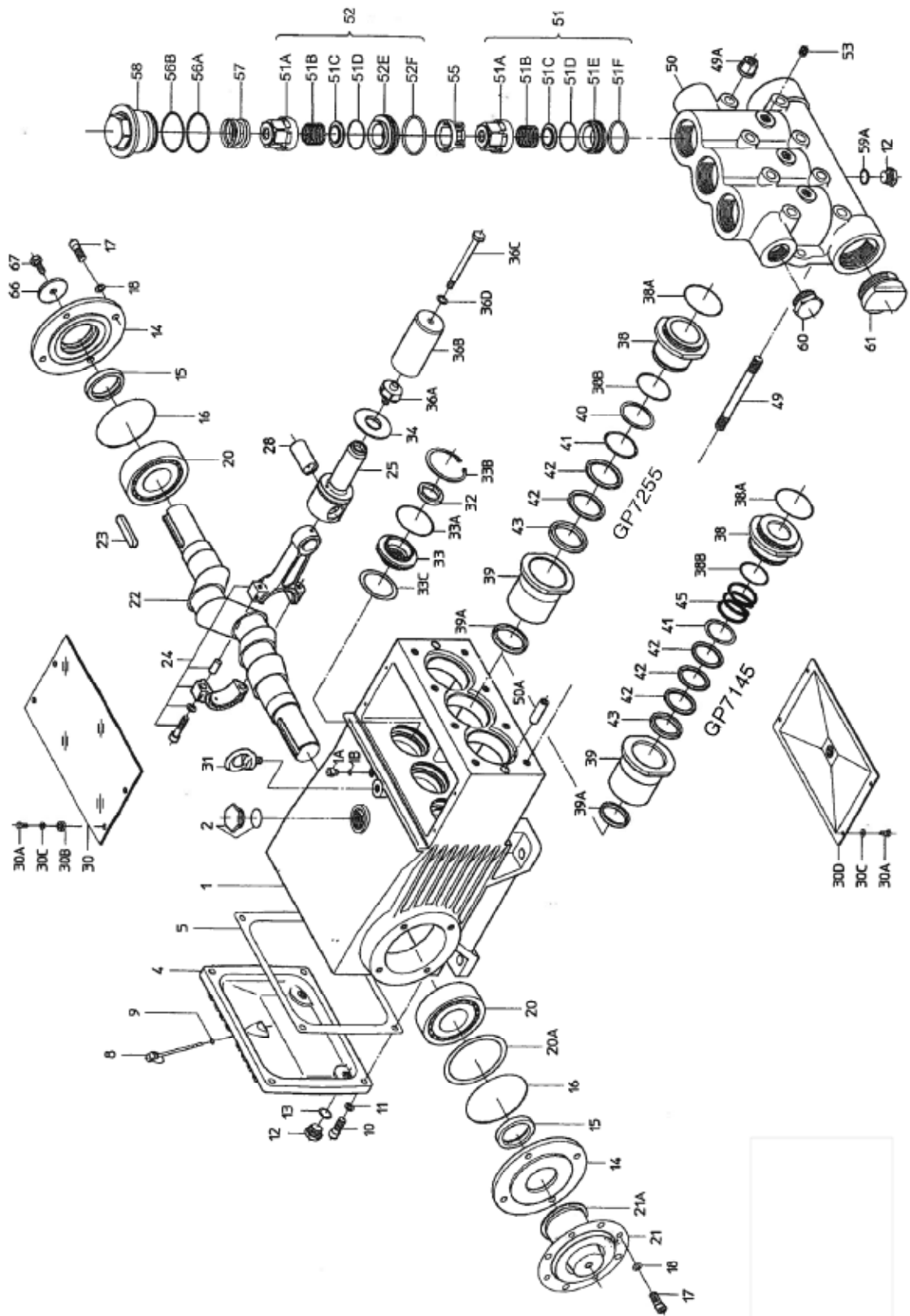

## PARTS LIST - GP7145 and GP7255A

<u>ITEM</u>	<u>PART</u>	<u>DESCRIPTION</u>	<u>QTY.</u>	<u>ITEM</u>	<u>PART</u>	<u>DESCRIPTION</u>	<u>QTY.</u>
1	07600	Crankcase	1	38	13155	Seal Case, GP7255A	3
1A	05525	Head for Oil Dipstick	1	38A	13156	O-Ring for 38	3
1B	01009	O-Ring	1	38B	06258	O-Ring for 38, GP7145	3
2	13000	Oil Filler Plug Assy.	1	38B	07721	O-Ring for 38, GP7255A	3
4	07601	Crankcase Cover	1	39	06171	Seal Sleeve, GP7145	3
5	07602	Gasket,Crankcase Cover	1	39	13157	Seal Sleeve, GP7255A	3
8	07603	Oil Dip Stick	1	39A	13290	Grooved Ring, GP7145	3
9	01009	O-Ring, Dip Stick	1	39A	07723	Grooved Ring, GP7255A	3
10	22706	Hexagon Screw	12	40	07797	Support Disc, GP7255 only	3
11	06725	Spring Washer	12	41	13296	Support Ring, GP7145	3
12	07109	Drain Plug	3	41	13158	Support Ring, GP7255A	3
13	07182	Gasket, Drain Plug	2	42	13294	V-Sleeve, GP7145	9
14	05644	Bearing Cover	2	42	07711	V-Sleeve, GP7255A	6
15	07608	Radial Shaft Seal	2	43	13293	Pressure Ring, GP7145	3
16	07184	O-Ring	2	43	07712	Pressure Ring, GP7255A	3
17	05642	Inner Hexagon Screw	8	45	13297	Tension Spring, GP7145 only	3
18	05039	Spring Washer	8	49	13159	Stud Bolt	8
20	07610	Taper Roller Bearing	2	49A	13160	Hexagon Nut	8
20A	07611	Fitting Disc (Shim)	1-5	50	07791	Valve Casing	1
21	05645	Holder for Shaft Protector	1	50A	13162	Cylinder Stud	2
21A	05646	Shaft Protector	1	51	05594	Inlet Valve Assembly (51A-51F)	3
22	13405	Crankshaft	1				
23	07614	Key	1	51A	05595	Sping Tension Cap	6
24	13182	Connecting Rod Assy.	3	51B	05450	Valve Spring	6
25	13183	Crosshead Assy.	3	51C	05247	Valve Plate	6
28	13184	Crosshead Pin	3	51D	05596	O-Ring	6
30	07619	Cover Plate	1	51E	05597	Inlet Valve Seat	3
30A	07225-0100	Hexagon Screw	8	51F	05166	O-Ring	3
30B	13136	Grommet	4	52	05600	Discharge Valve Assembly	3
30C	08280	Disc	8	52E	05598	Discharge Valve Seat	3
30D	13154	Cover Plate	1	52F	05599	O-Ring	3
31	07623	Eye Bolt	1	53	22610	Plug	3
32	07624	Radial Shaft Seal	3	55	05647	Valve Spacer	3
33	07626	Seal Retainer	3	56A	07658	O-Ring	3
33A	07627	O-Ring	3	56B	07635	Support Ring	3
33B	07628	Circlip	3	57	13173	Tension Spring	6
33C	07249	Fitting Disc	3	58	06682	Plug, M64 x 2	3
34	13137	Oil Scraper	3	59A	07661	Copper Ring for 12	1
36	06165	Plunger Pipe Assy. (36A-D), GP7145	3	60	12251	Plug, 1-1/4" NPT	1
36	07706	Plunger Pipe Assy. (36A-D), GP7255A	3	61	05170	Plug, 2-1/2" NPT	1
				66	13362	Disc For Crankshaft	1
				67	13358	Hexagon Screw	1
36A	07667	Plunger Connection	3		07662	Valve Tool (Not Shown)	1
36B	05157	Plunger Pipe, GP7145	3		05210	Plunger Conversion Assy. (36-45), GP7145	1
36B	07666	Plunger Pipe, GP7255A	3				
36C	06166	Tension Screw, GP7145	3		05211	Plunger Conversion Assy., (36-45), GP7255A	1
36C	07664	Tension Screw, GP7255A	3				
36D	07665	Copper Ring	3		17204	Valve Casing Assembly, (1x12/50-61 and 50A)	1
38	06167	Seal Case, GP7145	3		17212	Crankcase Assembly, (2x12/1-34/49/49A/52A/66/67)1	

## Repair Kits - GP7145 and GP7255A

### GP7145 / GP7255 Valve Repair Kits

#### Plunger Packing Kit - GP7145

##### # 09603

Item	Part #	Description	Qty.
38A	13156	O-Ring	3
38B	06258	O-Ring	3
39A	13290	Grooved Ring	3
41	13296	Support Ring	3
42	13294	V-Sleeve	9

#### Plunger Packing Kit - GP7255A

##### # 09220

Item	Part #	Description	Qty.
38A	13156	O-Ring	3
38B	07721	O-Ring	3
39A	07723	Grooved Ring	3
41	13158	Support Ring	3
42	07711	V-Sleeve	6

#### Oil Seal Kit

##### # 09221

Item	Part #	Description	Qty.
32	07624	Radial Shaft Seal	3
33A	07627	O-Ring	3

#### Inlet Valve Kit

##### # 09659

Item	Part #	Description	Qty.
51	05594	Inlet Valve Assembly	1
56A	07658	O-Ring	1
56B	07635	Support Ring	1

#### Large Discharge Valve Kit

##### # 09660

Item	Part #	Description	Qty.
52	05600	Discharge Valve Assembly	1
55	05647	Valve Spacer	1
56A	07658	O-Ring	1
56B	07635	Support Ring	1

#### Small Discharge Valve Kit \*

##### # 09661

Item	Part #	Description	Qty.
51B	05450	Valve Spring	1
51C	05247	Valve Plate	1
51D	05596	O-Ring	1
52F	05599	O-Ring	1
56A	07658	O-Ring	1
56B	07635	Support Ring	1

\* The discharge valve seat (item 52E) can be flipped over and used. If it is damaged on both sides, order kit # 09660.

### GP7145 and GP7255A Torque Specifications

Position	Item#	Description	Torque Amount
24	13182	Connecting Rod Assembly	30 ft.-lbs. (40 NM)
36C	06166/07664	Tension Screw	30ft.-lbs. (40 NM)
49A	13160	Hexagon Nut	103 ft.-lbs. (140 NM)
58	13170	Plug	107 ft-lbs (145 NM)

### Preventative Maintenance Check-List & Recommended Spare Part List

Check		Daily	Weekly	50hr	Every 500 hr	Every 1500 hr	Every 3000hr
Oil Level / Quality	X						
Oil Leaks		X					
Water Leaks		X					
Belts, Pulley			X				
Plumbing			X				
Recommended Spare Part							
Oil Change (p/n 01154)				X	X		
Plunger Packing Kits(1 kit/Pump)						X	
Oil Seal Kit ( 1 kit/Pump)						X	
Valve Kit ( 1 kit/pump)							X

## GP7145 and GP7255A Repair Instructions

### TO CHECK VALVES

Loosen plugs (58), take out tension spring (57) and then remove the complete valve assembly (#51 & 52) with either a valve tool or an M16 hexagon screw. Check sealing surfaces and replace worn parts. The discharge valve seat (# 52E) can be used on both sides. If you re-use it, make sure you switch the O-Ring (#51D) to the opposite side. Pumps manufactured after 10/07 are supplied with valve assemblies which screw together. Check O-rings and support rings. Tighten plugs (58) to 107 ft.-lbs. (145 NM).

### TO CHECK SEALS AND PLUNGER PIPE

Loosen nuts (49A) and remove pump head (50). Separate the plunger connection (36A) from the crosshead (25) by means of an open-end wrench (size 36mm). Pull seal sleeves (39) out of their fittings in the crankcase (1). Take the seal case (38) out of the seal sleeve (39). Examine the plunger parts (36A-36D), seals (42 & 39A) and O-rings (38A & 38B). When replacing the plunger pipe (36B), tighten tension screws (36C) to 30 ft. lbs. (40 NM). Replace worn parts; grease seals with Silicone before installing.

**CAUTION:** Don't loosen the (3) plunger connections (36A) before the valve casing has been removed otherwise the tension screw (36C) could hit against the valve adapter (56) when the pump is being turned. Seal life can be increased if the pre-tensioning allows for a little leakage. This assists lubrication and keeps the seals cool. It is therefore not necessary to replace seals before the leakage becomes too heavy and causes output and operating pressure to drop.

### MOUNTING VALVE CASING

Check O-rings (38A & 38B) on the seal case (38). Clean surfaces of seal sleeves in gear box and sealing surfaces of valve casing (50). Push the valve casing carefully on the O-rings of the seal case and centering studs (50A). Tighten nuts (49A) to 103 ft. lbs. (140 NM).

### TO DISASSEMBLE GEAR

Take out plunger (36) and seal sleeves (39) as described above. Drain the oil. After removing the circlip ring (33B), lever out seal retainer (33) with a screw driver. Check seals (32 & 33A) and surfaces of crosshead (25). Remove the crankcase cover (4). Loosen inner hexagon screws on the connecting rods (24).

**Note:** Connecting rods are marked for identification. Do not twist connecting rod halves. Each connecting rod is to be reinstalled in the same position (and orientation) on the crankshaft journals.

Push the connecting rod halves as far into the crosshead guide as possible. Check the surfaces of connecting rod and crankshaft (22). Take out the bearing cover (14) to one side and push out crankshaft taking particular care that the connecting rod doesn't bend. Re-assemble in reverse order. Regulate axial bearing clearance to a minimum of 0.1mm and a maximum of 0.15mm by means of fitting discs (20A). The crankshaft should turn easily and with little clearance. Tighten screws (24) to 30 ft.-lbs. (40 NM).

**Important!** The connecting rod has to be able to slightly move sideways at the crankshaft journal.

**Important!** Seal (32) must always be installed so that the seal-lip on the inside diameter faces the oil. Possible axial float of the seal retainer (33) should be compensated with the shims (33C).

<b>PUMP SYSTEM MALFUNCTIONS</b>		
<b><u>MALFUNCTION</u></b>	<b><u>CAUSE</u></b>	<b><u>REMEDY</u></b>
The Pressure and/ or the Delivery Drops	Worn packing seals	Replace packing seals
	Broken valve springs	Replace springs
	Belt slippage	Tighten or replace belt
	Worn or damaged nozzle	Replace nozzle
	Fouled discharge valve	Clean valve assembly
	Worn or plugged relief valve on pump	Clean, reset, and replace worn parts
	Cavitation	Check suction lines on inlet of pump for restrictions
Unloader	Check for proper operation	
Water in Crankcase	High humidity	Reduce oil change intervals
	Worn seals	Replace seals
Noisy Operation	Worn bearings	Replace bearings, Refill crankcase oil with recommended lubricant
	Cavitation	Check inlet lines for restrictions and/or proper sizing
Rough/Pulsating Operation with Pressure Drop	Worn packing	Replace packing
	Inlet restriction	Check system for stoppage air leaks, correctly sized inlet plumbing to pump
	Accumulator pressure	Recharge/replace accumulator
	Unloader	Check for proper operation
	Cavitation	Check inlet lines for restrictions and/or proper size
Pump Pressure as Drop at gun Rated, Pressure	Restricted discharge plumbing	Re-size discharge plumbing to flow rate of pump
Excessive Leakage	Worn plungers	Replace plungers
	Worn packing/seals	Adjust or replace packing seals
	Excessive vacuum	Reduce suction vacuum
	Cracked plungers	Replace plungers
	Inlet pressure too high	Reduce inlet pressure
High Crankcase Temperature	Wrong Grade of Oil	Giant oil is recommended
	Improper amount of oil in crankcase	Adjust oil level to proper amount

# GP7145 and GP7255A Dimensions - Inches (mm)

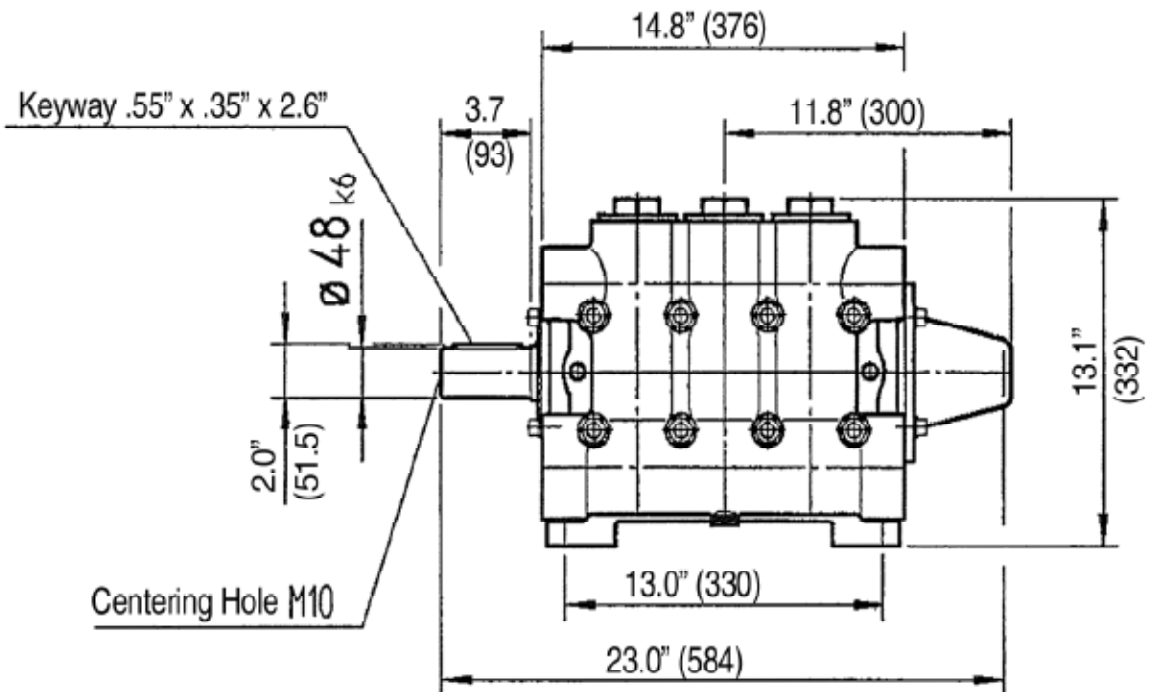
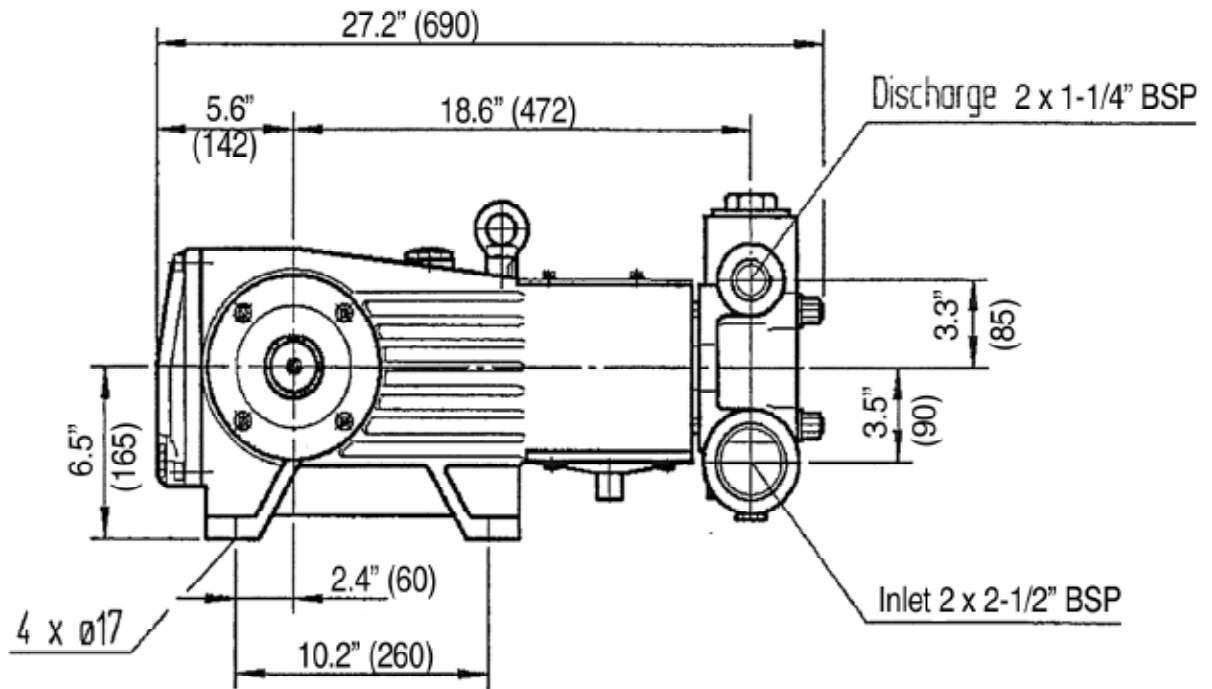

## GIANT INDUSTRIES LIMITED WARRANTY

Giant Industries, Inc. pumps and accessories are warranted by the manufacturer to be free from defects in workmanship and material as follows:

1. For portable pressure washers and self-service car wash applications, the discharge manifolds will never fail, period. If they ever fail, we will replace them free of charge. Our other pump parts, used in portable pressure washers and in car wash applications, are warranted for five years from the date of shipment for all pumps used in NON-SALINE, clean water applications.
2. One (1) year from the date of shipment for all other Giant industrial and consumer pumps.
3. Six (6) months from the date of shipment for all rebuilt pumps.
4. Ninety (90) days from the date of shipment for all Giant accessories.

This warranty is limited to repair or replacement of pumps and accessories of which the manufacturer's evaluation shows were defective at the time of shipment by the manufacturer. The following items are NOT covered or will void the warranty:

1. Defects caused by negligence or fault of the buyer or third party.
2. Normal wear and tear to standard wear parts.
3. Use of repair parts other than those manufactured or authorized by Giant.
4. Improper use of the product as a component part.
5. Changes or modifications made by the customer or third party.
6. The operation of pumps and or accessories exceeding the specifications set forth in the Operations Manuals provided by Giant Industries, Inc.

Liability under this warranty is on all non-wear parts and limited to the replacement or repair of those products returned freight prepaid to Giant Industries which are deemed to be defective due to workmanship or failure of material. A Returned Goods Authorization (R.G.A.) number and completed warranty evaluation form is required prior to the return to Giant Industries of all products under warranty consideration. Call (419)-531-4600 or fax (419)-531-6836 to obtain an R.G.A. number.

Repair or replacement of defective products as provided is the sole and exclusive remedy provided hereunder and the MANUFACTURER SHALL NOT BE LIABLE FOR FURTHER LOSS, DAMAGES, OR EXPENSES, INCLUDING INCIDENTAL AND CONSEQUENTIAL DAMAGES DIRECTLY OR INDIRECTLY ARISING FROM THE SALE OR USE OF THIS PRODUCT.

THE LIMITED WARRANTY SET FORTH HEREIN IS IN LIEU OF ALL OTHER WARRANTIES OR REPRESENTATION, EXPRESS OR IMPLIED, INCLUDING WITHOUT LIMITATION ANY WARRANTIES OR MERCHANTABILITY OR FITNESS FOR A PARTICULAR PURPOSE AND ALL SUCH WARRANTIES ARE HEREBY DISCLAIMED AND EXCLUDED BY THE MANUFACTURER.



**GIANT INDUSTRIES, INC.**

900 N. Westwood Ave.

Toledo, Ohio 43607

Phone: (419) 531-4600

Fax: (419) 531-6836

© Copyright 2010 Giant Industries, Inc.

[www.giantpumps.com](http://www.giantpumps.com)