

Model GP7124A-4000

Triplex Ceramic
Plunger Pump
Operating Instructions/
Repair and Service
Manual



Contents:

Installation Instructions:	page 2
Pump Specifications:	page 3
Exploded View:	page 4
Parts List:	page 5
Kits:	page 6
Torque Specifications:	page 6
Recommended Spare Parts List:	page 6
Repair & Service:	pages 7-10
Dimensions:	page 11
Warranty Information:	back page

INSTALLATION INSTRUCTIONS

Installation of the Giant Industries, Inc., pump is not a complicated procedure, but there are some basic steps common to all pumps. The following information is to be considered as a general outline for installation. If you have unique requirements, please contact Giant Industries, Inc. or your local distributor for assistance.

1. The pump should be installed flat on a base to a maximum of a 15 degree angle of inclination to ensure optimum lubrication. If the pump is mounted on a vehicle with the possibility of unlevelness, or the pump speed is between 300 & 500 RPM, the oil quantity should be increased to 1.9 gal.(7.0 liters). To check, put the oil dipstick in the bore next to the lifting eye bolt.
2. The inlet to the pump should be sized for the flow rate of the pump with no unnecessary restrictions that can cause cavitation. Teflon tape should be used to seal all joints. If pumps are to be operated at temperatures in excess of 140°F, it is important to insure a positive head to the pump to prevent cavitation.
3. The discharge plumbing from the pump should be properly sized to the flow rate to prevent line pressure loss to the work area. It is essential to provide a safety bypass valve between the pump and the work area to protect the pump from pressure spikes in the event of a blockage or the use of a shut-off gun.
4. Use of a dampener is necessary to minimize pulsation at drive elements, plumbing, connections, and other system areas. The use of a dampener with Giant Industries, Inc. pumps is optional, although recommended by

Giant Industries, Inc. to further reduce system pulsation. Dampeners can also reduce the severity of pressure spikes that occur in systems using a shut-off gun. A dampener must be positioned downstream from the unloader.

5. Crankshaft rotation on Giant Industries, Inc. pumps should be made in the direction designated by the arrows on the pump crankcase. Reverse rotation may be safely achieved by following a few guidelines available upon request from Giant Industries, Inc. Required horsepower for system operation can be obtained from the chart on page 3. While in operation, all rotating parts must be covered. The open shaft end by the shaft protector (21), the driven shaft side and coupling by a protective guard. Plunger area must have cover plate (30) secured in place. Do not step on or place weight on the cover (30).
6. Before beginning operation of your pumping system, remember: Check that the crankcase and seal areas have been properly lubricated per recommended schedules. Do not run the pump dry for extended periods of time. Cavitation will result in severe damage. Always remember to check that all plumbing valves are open and that pumped media can flow freely to the inlet of the pump.

Finally, remember that high pressure operation in a pump system has many advantages. But, if it is used carelessly and without regard to its potential hazard, it can cause serious injury.

IMPORTANT OPERATING CONDITIONS **Failure to comply with any of these** **conditions invalidates the warranty**

1. Prior to initial operation, add oil to crankcase so that the oil level is between the two lines on the oil dipstick. **DO NOT OVERFILL.**

Use SAE 90 Gear Oil (ISO VG 220) (1.6 Gal)
SAE 80 (ISOVG 68 for 40° F or below)

Crankcase oil should be changed after the first 50 hours of operation, then at regular intervals of 500 hours or less depending on operating conditions.

2. When operating in high humidity or wide temperature fluctuations, oil must be changed, at once, when condensate or milky colored oil is found.
3. Pressure in discharge line and pump must be at zero before any maintenance is performed on the pump. Close the inlet line and disconnect the motor circuit to prevent accidental starting. Make sure that all parts on the pressure side of the unit are vented and refilled, with

pressure at zero, before restarting the pump. In order to prevent air, or an air/water-mixture being absorbed and to prevent cavitation from occurring, the pump-npshr, positive suction head and water temperature must be controlled.

Cavitation can lead to uncontrollable pressure kicks which can damage the pump or accessories and can be dangerous to the operator or anyone standing nearby.

4. Pump operation must not exceed rated pressure, volume or RPM. A pressure relief device must be installed in the discharge of the system.
5. Acids, alkalines, or abrasive fluids cannot be pumped unless approval in writing is obtained before operation from Giant Industries, Inc.
6. Run the pump dry approximately 10 seconds to drain the water before exposure to freezing temperatures.

* **Important**-Check torque bi-weekly on item 49A

Specifications

Model GP7124A-4000

Volume	Up to 12.7 GPM (48 LPM)
Discharge Pressure	Up to 7,250 PSI (500 bar)
Discharge Pressure* (Intermittent Duty-See chart below)	Up to 10,000 PSI (690 bar)*
Speed	Up to 750 RPM
Inlet Pressure	Up to 90 PSI ¹ (10 bar)
Plunger Diameter94"(24mm)
Plunger Stroke	2.1"(52mm)
Crankshaft Diameter	1.9"(48mm)
Key Width55"(14mm)
Crankshaft Mounting	Either side
Shaft Rotation	Top of pulley towards manifold
Temperature of Pumped Fluids	Up to 140 °F (60°C)
Inlet Ports	(2) 1 1/4" NPT
Discharge Ports	(2) 3/4" NPT
Weight	374 lbs. (170 kg)
Crankcase Oil Capacity	1.6 Gal. (6.0 liters)
Fluid End Material	Stainless Steel
Volumetric Efficiency @ 700 RPM	89%
Mechanical Efficiency @ 700 RPM	83%

¹Positive inlet pressures are recommended!

Consult the factory for special requirements that must be met if the pump is to operate beyond one or more of the limits specified above.

RPM	GPM	10,000 PSI*
600	10.1	69.9HP

*** FOR INTERMITTENT DUTY ONLY!**

MUST RUN PUMP WITH A DUMP GUN AND SAFETY VALVE!
NO UNLOADER OR REGULATOR TO UNLOAD PUMP!

GP7124A PULLEY SELECTION & HORSEPOWER REQUIREMENTS - ELECTRIC MOTOR							
PUMP PULLEY	MOTOR PULLEY	RPM	GPM	3000 PSI	5000 PSI	6000 PSI	7250 PSI
12.75	5.30	300	5.1	10.5	17.6	21.1	25.5
12.75	7.00	400	6.8	14.1	23.4	28.1	34.0
12.75	9.45	550	9.3	19.2	32.1	38.5	46.5
12.75	10.30	600	10.1	20.9	34.8	41.8	50.5
12.75	11.10	650	11.0	22.8	37.9	45.5	55.0
12.75	11.90	700	11.8	24.4	40.7	48.8	59.5
12.75	12.75	750	12.7	26.3	43.8	52.6	63.5

HORSEPOWER RATINGS:

The ratings shown in the chart above reflect the horsepower requirements for electric motors. We recommend motors with a 1.15 service factor.

To compute specific pump horsepower requirements, use the following formula:

$$\frac{\text{GPM} \times \text{PSI}}{1450} = \text{hp}$$

GP7124A-4000 PARTS LIST

ITEM	PART	DESCRIPTION	QTY.	ITEM	PART	DESCRIPTION	QTY.
1	07600	Crankcase	1	39B	06954	Support Ring for 39A	3
1A	05525	Head for Oil Dipstick	1	39B**	07693**	Support Ring	6
1B	01009	O-Ring	1	39C	07332	O-Ring	3
2	13000	Oil Filler Plug Assembly	1	39D	07683	Support Ring for 39C	3
4	07601	Crankcase Cover	1	40	13143	Tension Spring	3
5	07602	Seal for Crankcase Cover	1	40**	13400**	Grooved Seal	3
8	07603	Oil Dip Stick	1	41	06955	Support Disc	3
9	01009	O-Ring, Dip Stick	1	41**	07718**	Support Ring	3
10	22706	Hexagon Screw	12	42	07685	Spiral Ring (Packing)	6
11	06725	Spring Washer	12	43	07718	Support Ring	6
12	07109-0400	Drain Plug	5	43**	13410**	Teflon Support Ring	3
13	07182	Gasket, Drain Plug	2	44	06956	Guide Ring	3
14	07607	Bearing Cover	2	45	06957	Pressure Ring	3
15	07608	Radial Shaft Seal	2	46	07169	Leakage Seal	3
16	07184	O-Ring for Bearing Cover	2	49	13159	Stud Bolt	8
20	07610	Taper Roller Bearing	2	49A	06958	Hexagon Nut	8
20A	07611	Fitting Disc (Shim)	1-5	50	06759	Valve Casing	1
21	07612	Shaft Protector	1	50A	13162	Centering Stud	2
22	13405	Crankshaft	1	51B	05193	O-Ring	6
23	07614	Key	1	51C	05194	Inlet Valve Seat	3
24	13182	Connecting Rod Assy.	3	51D	06761	Valve Plate	6
25	13183	Crosshead Assy.	3	51E	06762	Valve Spring	6
28	13184	Crosshead Pin	3	51F	06763	Spacer Pipe	6
30	07619	Cover Plate	1	52C	05195	Discharge Valve Seat	3
30A	07225-0100	Hexagon Screw	8	57	06078	Tension Spring	3
30B	13136	Grommet	4	58	07699	Plug	3
30C	08280	Disc	8	58A	07700	O-Ring	3
30D	13154	Cover	1	58B	07693	Support Ring	3
31	07623	Eye Bolt	1	58C	07702	Hexagon Screw	12
32	07624	Radial Shaft Seal	3	59A	06807	Copper Ring (Gasket)	3
33	06950	Seal Retainer	3	60	13150-0100	Plug 3/4" BSP	1
33A	07627	O-Ring for Seal Retainer	3	61	13151	Plug 1-1/4" BSP	1
33B	06951	Circlip for Seal Retainer	3	62	06765	Connecting Screw	2
33C	07249	Fitting Disc	3	62A	06766	Connection Ring	2
34	13137	Oil Scraper (Flinger)	3	62B	06767	Seal Ring	4
36	13138	Plunger	3	64	07204-0100	Steel Ring	2
38	06952	Seal Sleeve	3	66	13362	Disc for Crankshaft	1
38A	22764	Serrated Pin	3	67	13358	Hexagon Screw	1
38B	06750	Leakage Gasket	3	69	06588	Screw-in Connector	2
38C	06667	O-Ring	3	70	06768	Threaded Elbow	2
39	06953	Seal Case	3	71	06769	Curved Leakage Pipe	2
39A	07150	O-Ring	3				
39A**	12055**	O-Ring	6				

** For Pumps manufactured before 7/01

GP7124A-4000 REPAIR KITS

Plunger Packing Kit #09224

Item	Part #	Description	Qty.
38B	06750	Leakage Gasket	3
38C	06667	O-Ring	3
39A	07150	O-Ring	3
39B	06954	Support Ring	3
39C	07332	O-Ring	3
39D	07683	Support Ring	3
42	07685	Packing	6
43	07718	Support Ring	6
44	06956	Guide Ring	3
46	07169	Seal Ring	3

Plunger Packing Kit # 09583

(For pumps manufactured before 7/01)

Item	Part #	Description	Qty.
39A	12055	O-Ring	6
39B	07693	Support Ring	6
40	13400	Grooved Seal	3
41	07718	Support Ring	3
42	07685	Packing	3
43	13410	Teflon Support Ring	3

Inlet Valve Assembly Kit #09226

Item	Part #	Description	Qty.
51B	05193	O-Ring	1
51C	05194	Inlet Valve Seat	1
51D	06761	Valve Plate	1
51E	06762	Valve Spring	1

Discharge Valve Assembly Kit #09227

Item	Part #	Description	Qty.
51B	05193	O-Ring	1
51D	06761	Valve Plate	1
51E	06762	Valve Spring	1
52C	05195	Discharge Valve Seat	1

Oil Seal Kit #09225

Item	Part #	Description	Qty.
32	07624	Radial Shaft Seal	3
33A	07627	O-Ring	3

GP7124A-4000 TORQUE SPECIFICATIONS

Position	Item#	Description	Torque Amount
36	13138	Plunger	26 (ft.-lbs.)
*49A	13160	Nut	103 (ft.-lbs.)
58C	07702	Hexagon Screw	155 (ft.-lbs.)

* **Important** - Check torque bi-weekly on item 49A

Preventative Maintenance Check-List & Recommended Spare Parts List						
Check	Daily	Weekly	50hrs	Every 500 hrs	Every 1500 hrs	Every 3000 hrs
Oil Level/Quality	X					
Oil Leaks	X					
Water Leaks	X					
Belts, Pulley		X				
Plumbing		X				
Recommended Spare Parts						
Oil Change			X	X		
Plunger Spare Parts (1 kit/pump) (See page 6 for kit list)					X	
Oil Seal Kit (1 kit/pump) (See page 6 for kit list)					X	
Valve Spare Parts (1 kit/pump) (See page 6 for kit list)						X

GP7124A-4000 REPAIR INSTRUCTIONS

NOTE: Always take time to lubricate all metal and non-metal parts with a light film of oil before reassembling. This step will help ensure proper fit, at the same time protecting the pump non-metal parts (elastomers) from cutting and scoring.

TO CHECK VALVES



1) Loosen and remove screws (58C) with a 24mm socket wrench.



2) Take plugs (58) out of valve casing (50) by tightening screws (58C) against valve casing with two screws.

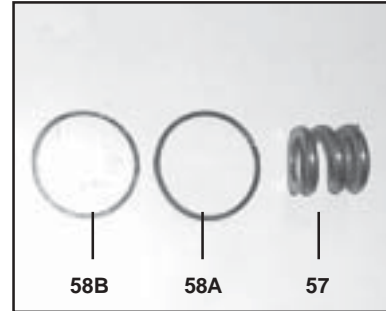

3) Remove the compression spring (57) O-Ring (58A) and support ring (58B).



4) Take out valve assemblies (51 & 52) using either tool (part #07662) or a stud bolt(M16).



5) Valve seats (51C and 52C) are pressed out of spacer pipe (51F) by hitting the valve plate (51D) with a socket extension.

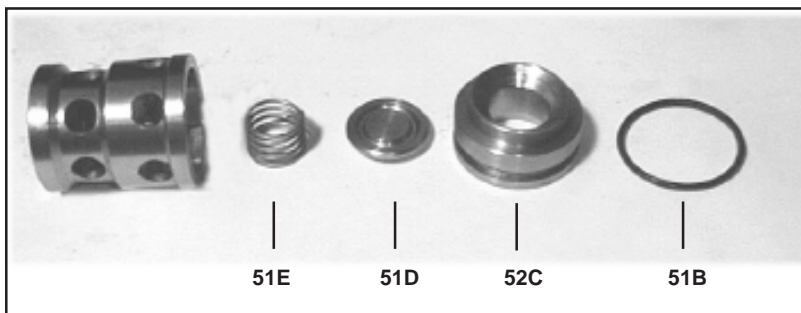

6) Check surfaces of valve plate (51D), valve seat(51C, 52C), O-rings (51B, 58A) and replace worn parts.

GP7124A -4000 REPAIR INSTRUCTIONS

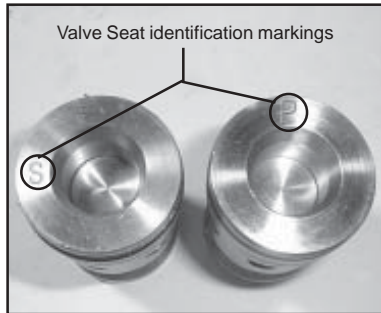

- 7) When reassembling: The inlet valve seat (51C) is 1mm smaller in diameter than the discharge valve seat (52C). Inlet valve seats are marked "S" and always have to be installed first. Discharge valve seats are marked "P" and are always to be installed on top of inlet valve. Plugs (58) are to be tensioned down evenly with screws (58C) and in crosswise pattern at 155 (ft.lbs.).

TO CHECK SEALS

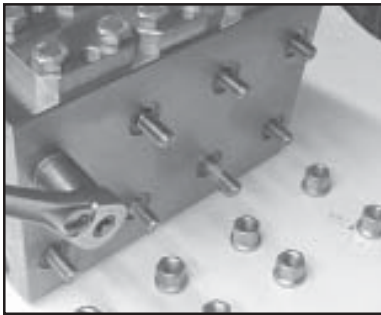

- 8) Loosen nuts (49A) with a 24mm socket wrench.

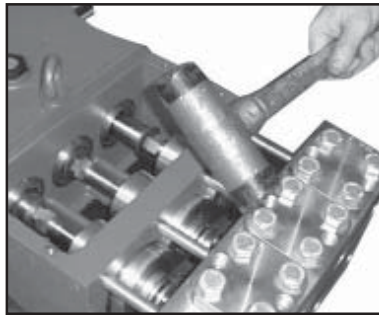

- 9) With a rubber mallet tap the back of the valve casing (50) and pull the valve casing off the stud bolt (49).



- 10) Remove cover plate (30) with a 10mm socket wrench.

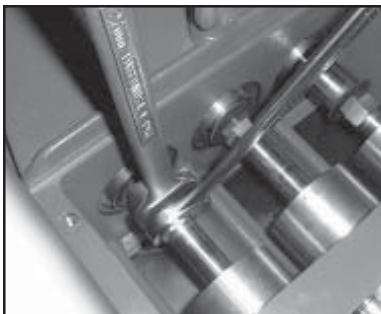

- 11) Using a 27mm wrench, separate the plunger (36) from the crosshead (25). NOTE: DO NOT loosen the three (3) plungers (36) before the the valve casing has been removed otherwise the plunger could hit against the spacer pipe (51F) when pump is being turned

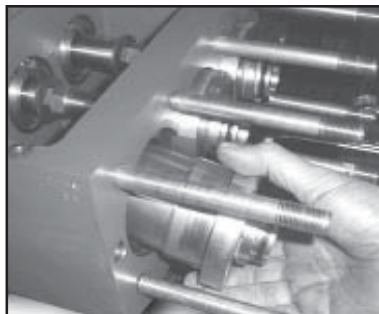

- 12) Pull seal sleeves (38) out of their fittings in the crankcase (1).

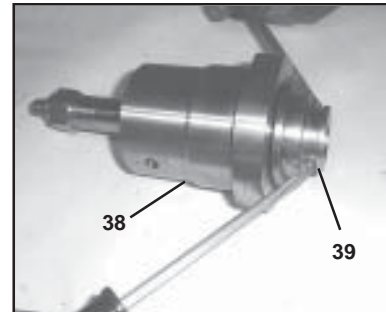

- 13) Use two screwdrivers to pry the seal case (39) from the seal sleeve (38).

GP7124A-4000 REPAIR INSTRUCTIONS

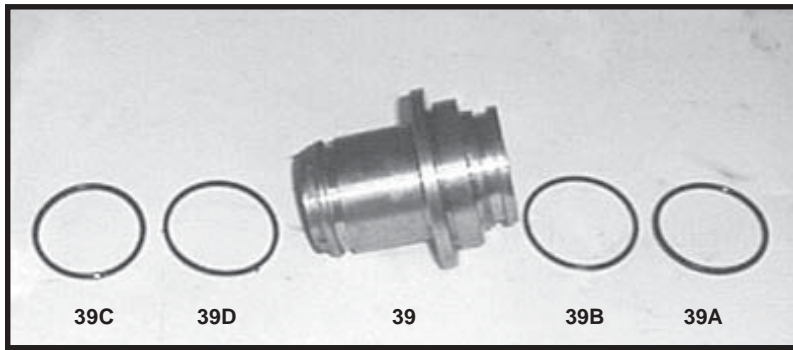

14) Remove and replace O-rings (39A, 39C) on support rings (39B, 39D).

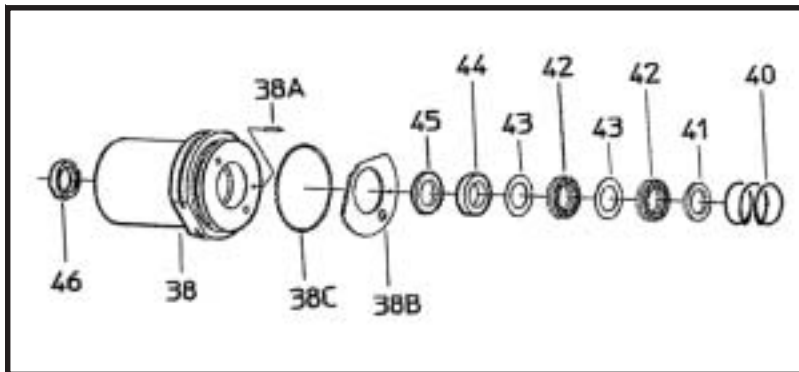

15) Remove grooved seal (46) from seal sleeve. Take pressure spring (40), support disc (41), seal unit (42, 43, 44) and pressure ring (45) out of seal sleeve (38). Remove leakage gasket (38B) from serated pin (38A) on seal sleeve (38). Replace worn parts from kit # 09224.

IMPORTANT! The leakage gasket (38B) must be fitted to the seal sleeve (38) so that the bevelled surface of the gasket (38B) faces outward.

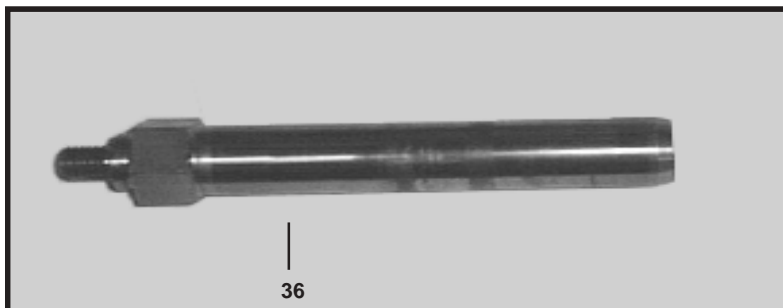

16) Check plunger (36) surface. Replace worn seals.

NOTE: Seal life can be increased if the pretensioning allows for a little leakage. This assists lubrication and keeps the seals cool. It is therefore not necessary to replace seals before the leakage becomes too heavy and causes output and operating pressure to drop.

GP7124A-4000 REPAIR INSTRUCTIONS

TO ASSEMBLE VALVE CASING

- 17) Replace seal assembly in reverse order. Insert plunger through the back of the seal sleeve (38) by placing a pipe in the front of the seal sleeve (38) to hold the seal assembly in place.
- 18) Push seal case (39) into seal sleeve (38). Insert seal sleeve with plunger (36) into crankcase guide with weep holes facing down. Tighten plunger(36) to 33 ft-lbs with a 27mm torque wrench.
19. Push valve casing carefully over O-rings of seal case and centering studs (50A). Tighten nuts (49A) to space 103 ft-lbs.

TO DISASSEMBLE GEAR END

20. Take out plunger (36) and seal sleeves (38) as described above. Drain oil.
21. After removing the circlip ring (33B), pry out seal adapter (33) with a screw driver
22. Check seals (32), o-ring (33A) and surfaces of plunger base (25).
23. Remove crankcase cover (4). Loosen inner hexagon screws on the connecting rods (24) and push conn rod halves as far into the crosshead guide as possible.

CAUTION: Connecting rods (24) are marked for identification. Do not twist connecting rod halves. Connecting rod is to be reinstalled in the same position on crankshaft journals.

24. Check surfaces of the connecting rod (24) and crankshaft (22).
25. Take out bearing cover (14) to one side and push out crankshaft (22) taking particular care that the connecting rod (24) doesn't bend.
26. Reassemble in reverse order: Regulate axial bearing clearance - minimum 0.1mm, maximum 0.15mm-by means of fitting disc (20A). The crankshaft (22) should turn easily with little clearance. Tighten inner hexagon screws to 30 ft.-lbs.

CAUTION: Connecting rod (24) has to be able to be slightly moved sidewise at the stroke journals.

27. Reassemble cover (4) and seal (5) onto crankcase (1). Fasten with hexagon screws (10).
28. Reinstall shim (33C), and seal adaptor (33) with radial shaft seal (32) and o-ring (33A) onto crankcase (1).
29. Reinstall remainder of fluid end as described above in "To Assemble Valve Casing" section (17-19).

GP7124A-4000 Dimensions - inches (mm)

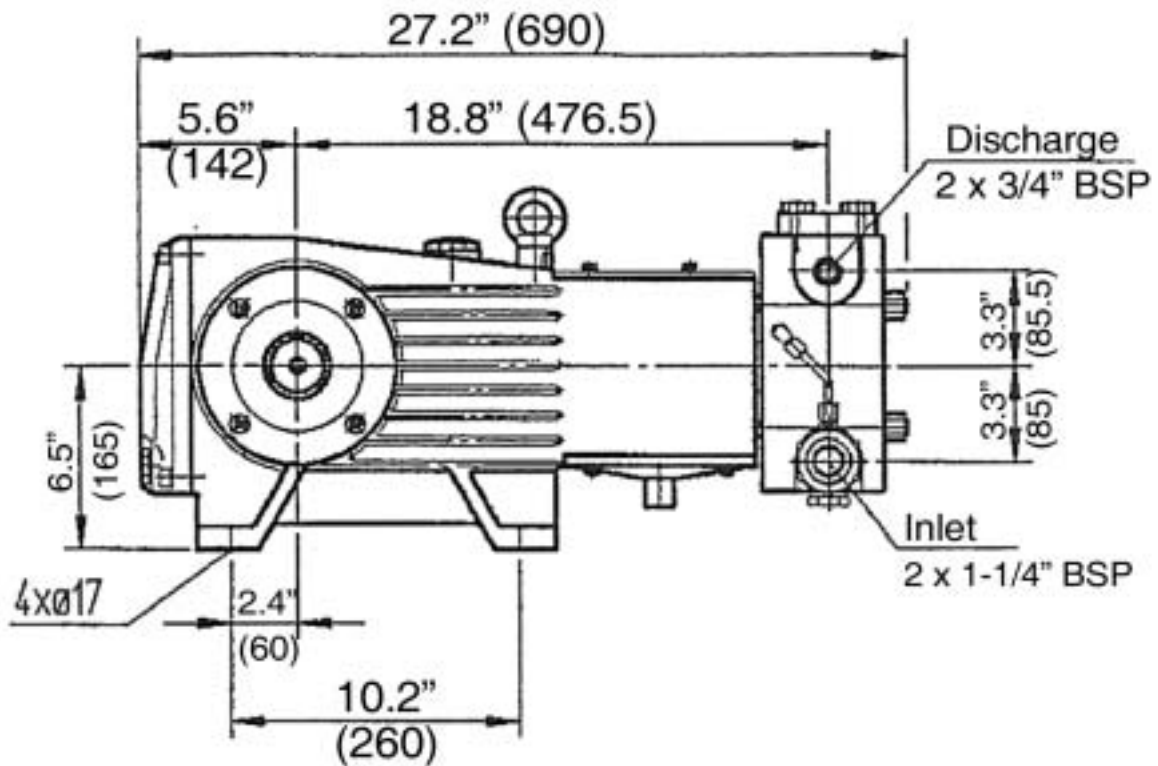
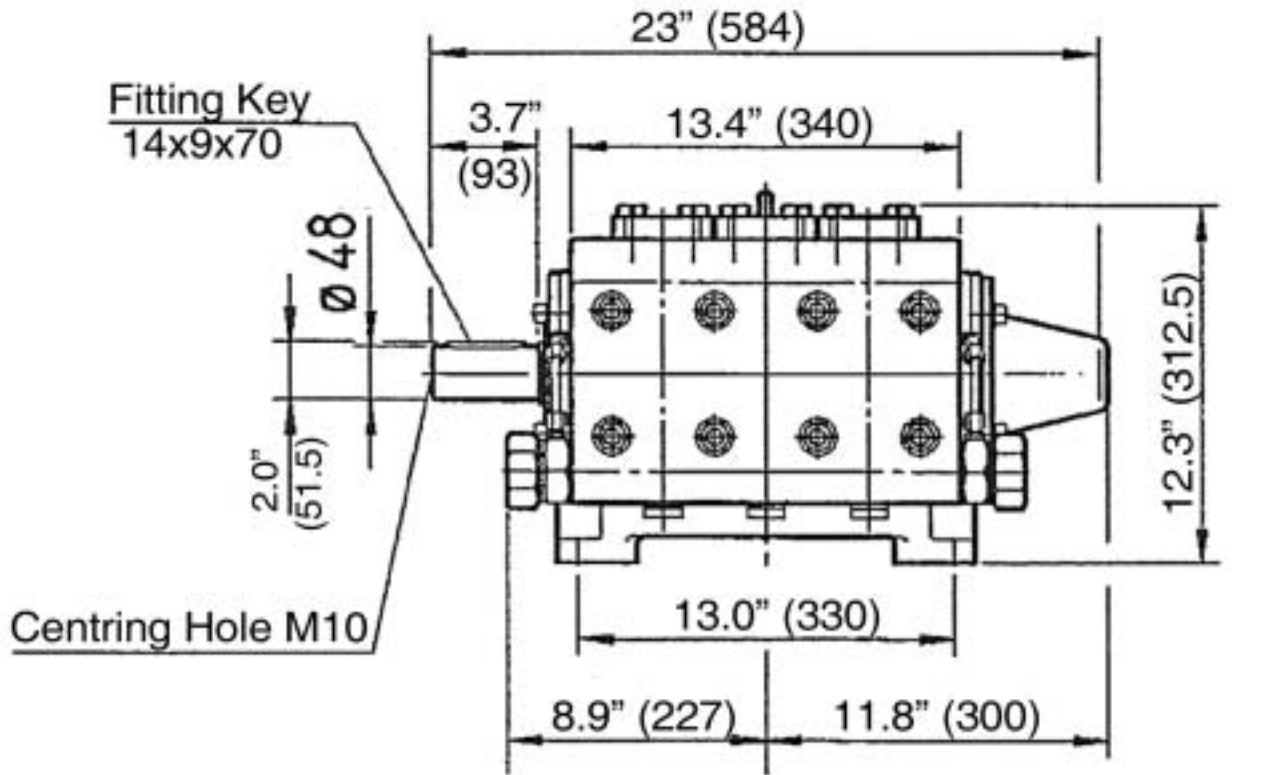

GIANT INDUSTRIES LIMITED WARRANTY

Giant Industries, Inc. pumps and accessories are warranted by the manufacturer to be free from defects in workmanship and material as follows:

1. For portable pressure washers and car wash applications, the discharge manifolds will never fail, period. If they ever fail, we will replace them free of charge. Our other pump parts, used in portable pressure washers and in car wash applications, are warranted for five years from the date of shipment for all pumps used in NON-SALINE, clean water applications.
2. One (1) year from the date of shipment for all other Giant industrial and consumer pumps.
3. Six (6) months from the date of shipment for all rebuilt pumps.
4. Ninety (90) days from the date of shipment for all Giant accessories.

This warranty is limited to repair or replacement of pumps and accessories of which the manufacturer's evaluation shows were defective at the time of shipment by the manufacturer. The following items are NOT covered or will void the warranty:

1. Defects caused by negligence or fault of the buyer or third party.
2. Normal wear and tear to standard wear parts.
3. Use of repair parts other than those manufactured or authorized by Giant.
4. Improper use of the product as a component part.
5. Changes or modifications made by the customer or third party.
6. The operation of pumps and or accessories exceeding the specifications set forth in the Operations Manuals provided by Giant Industries, Inc.

Liability under this warranty is on all non-wear parts and limited to the replacement or repair of those products returned freight prepaid to Giant Industries which are deemed to be defective due to workmanship or failure of material. A Returned Goods Authorization (R.G.A.) number and completed warranty evaluation form is required prior to the return to Giant Industries of all products under warranty consideration. Call (419)-531-4600 or fax (419)-531-6836 to obtain an R.G.A. number.

Repair or replacement of defective products as provided is the sole and exclusive remedy provided hereunder and the MANUFACTURER SHALL NOT BE LIABLE FOR FURTHER LOSS, DAMAGES, OR EXPENSES, INCLUDING INCIDENTAL AND CONSEQUENTIAL DAMAGES DIRECTLY OR INDIRECTLY ARISING FROM THE SALE OR USE OF THIS PRODUCT.

THE LIMITED WARRANTY SET FORTH HEREIN IS IN LIEU OF ALL OTHER WARRANTIES OR REPRESENTATION, EXPRESS OR IMPLIED, INCLUDING WITHOUT LIMITATION ANY WARRANTIES OR MERCHANTABILITY OR FITNESS FOR A PARTICULAR PURPOSE AND ALL SUCH WARRANTIES ARE HEREBY DISCLAIMED AND EXCLUDED BY THE MANUFACTURER.

Giant Industries, Inc.
900 N. Westwood Ave.
Toledo, OH 43607
419-531-4600



419-531-6836 Fax
www.giantpumps.com
© 2009 Giant Industries, Inc.